

Marzenna Grochowalska · Margaryta Orzechowska

Punktowce

ćwiczenia rozgrzewkowe dla klas 4-6



Punktowce

ćwiczenia rozgrzewkowe dla klas 4-6



1. Narysuj odcinek AC, którego długość jest równa długości odcinka AB.

Przykładowe rozwiązanie:

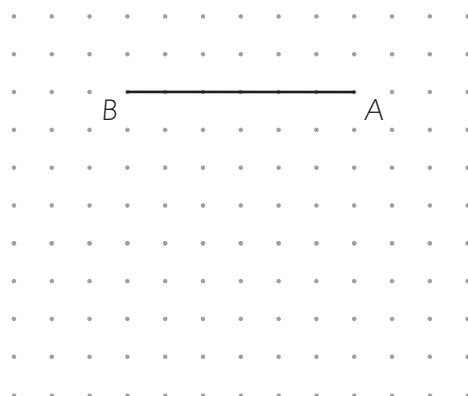
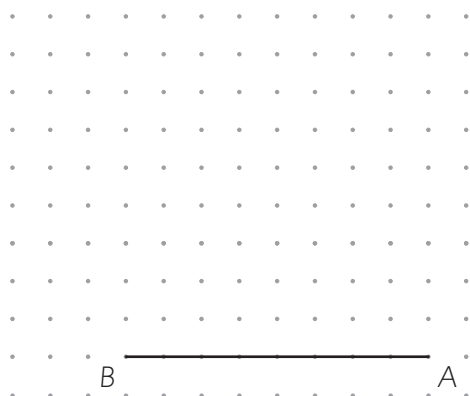
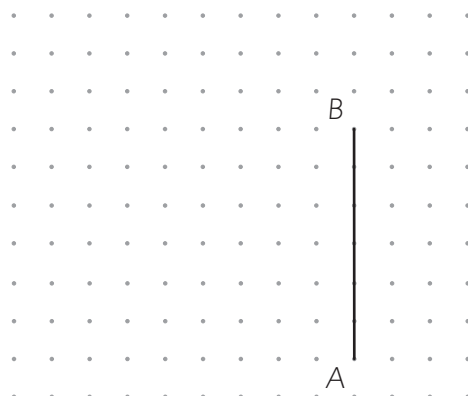
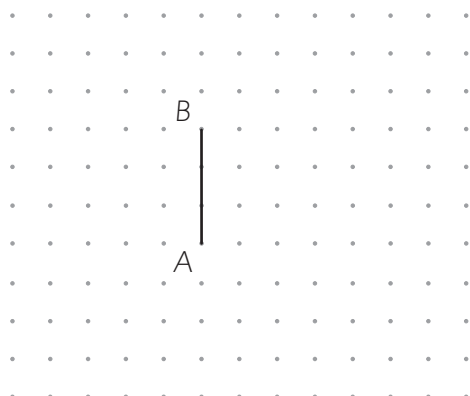
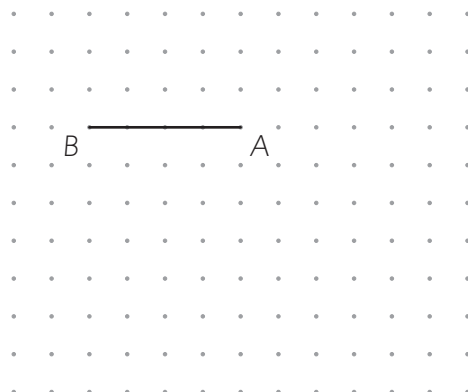
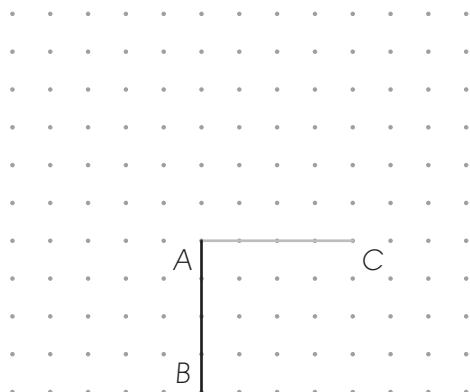

Punktowce dla klas 1–8 to nowatorskie ćwiczenia do rozwijania wyobraźni geometrycznej. Kupisz na www.księgarnia.gwo.pl



Punktowce

ćwiczenia rozgrzewkowe dla klas 4-6



2. Narysuj dwa odcinki: AC i AD, których długość jest równa długości odcinka AB.

Przykładowe rozwiązanie:

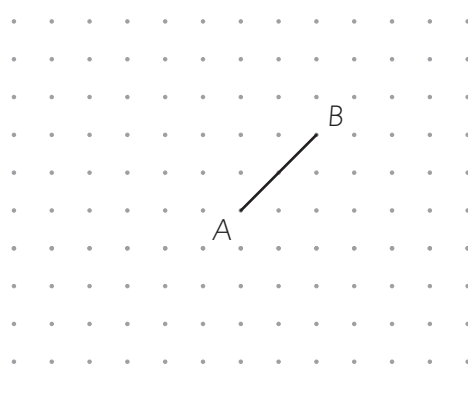
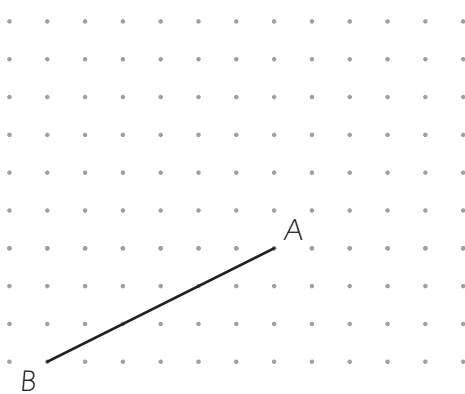
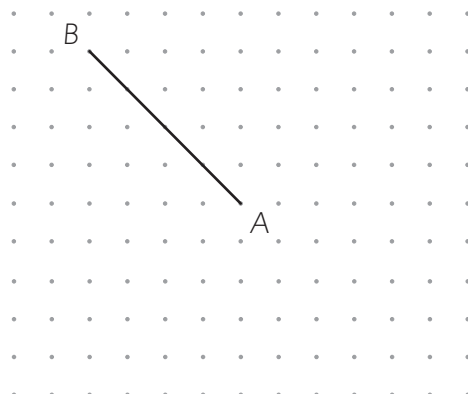
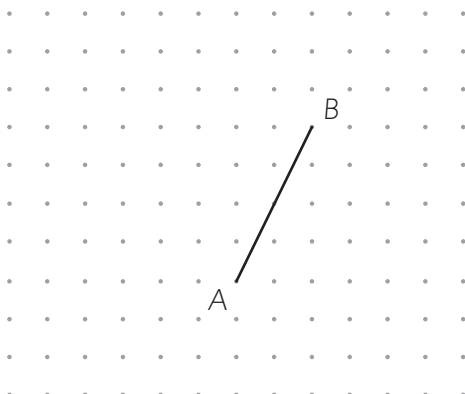
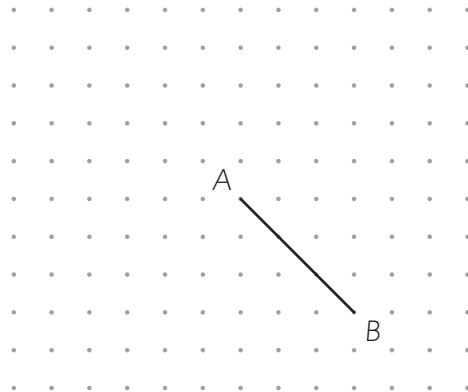
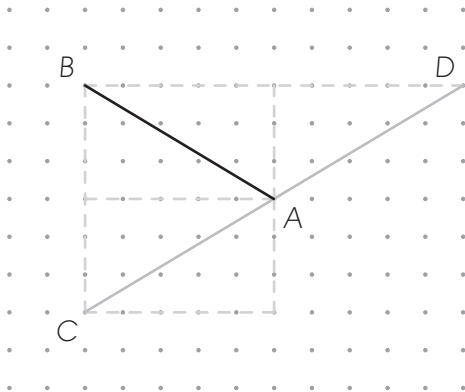

Punktowce dla klas 1–8 to nowatorskie ćwiczenia do rozwijania wyobraźni geometrycznej. Kupisz na www.księgarnia.gwo.pl

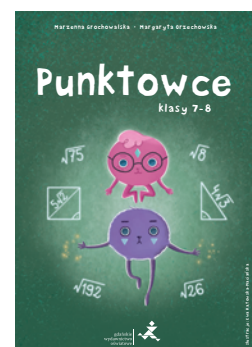

Punktowce

ćwiczenia rozgrzewkowe dla klas 4-6



3. Narysuj cztery odcinki: AC, AD, AE i AF, każdy o długości równej długości odcinka AB.

Przykładowe rozwiązanie:

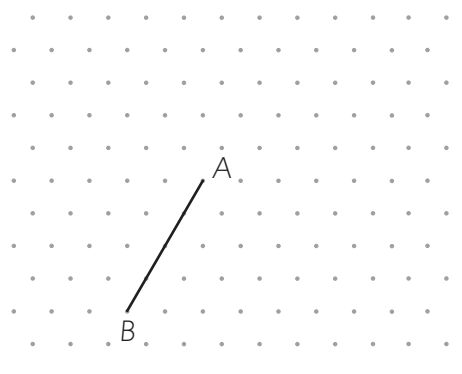
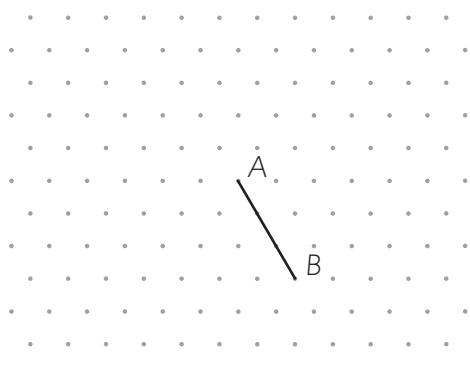
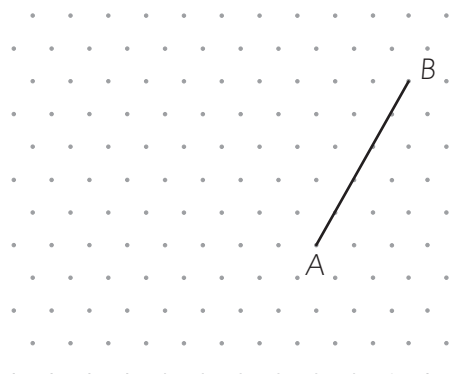
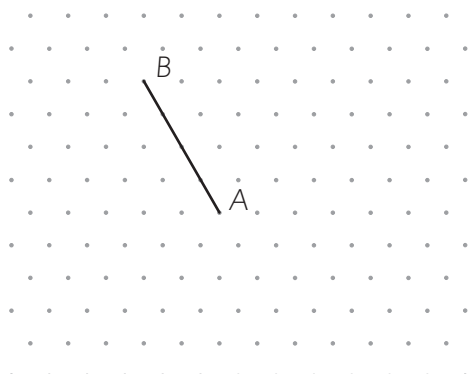
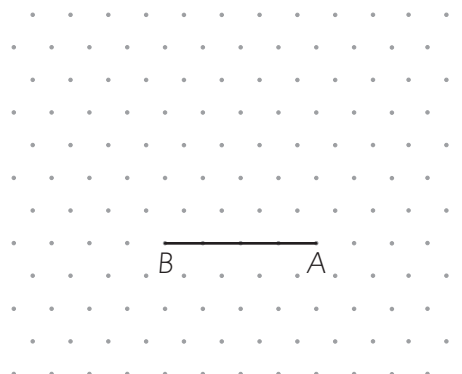
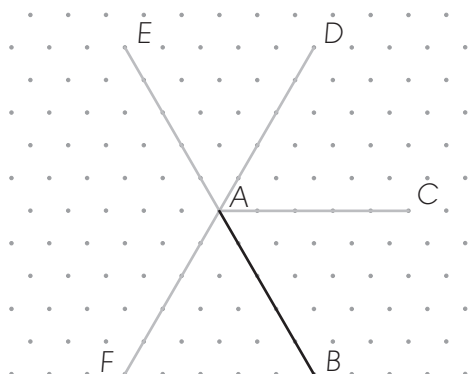

Punktowce dla klas 1-8 to nowatorskie ćwiczenia do rozwijania wyobraźni geometrycznej. Kupisz na www.ksiegarnia.gwo.pl

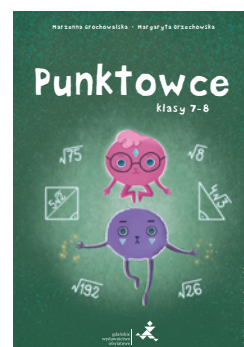

Punktowce

ćwiczenia rozgrzewkowe dla klas 4-6



4. Narysuj dwa odcinki: AC i AD, których długość jest równa długości odcinka AB.

Przykładowe rozwiązanie:

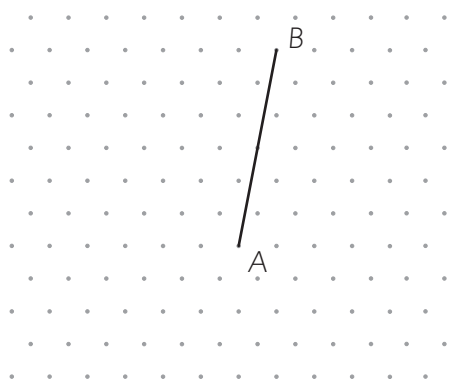
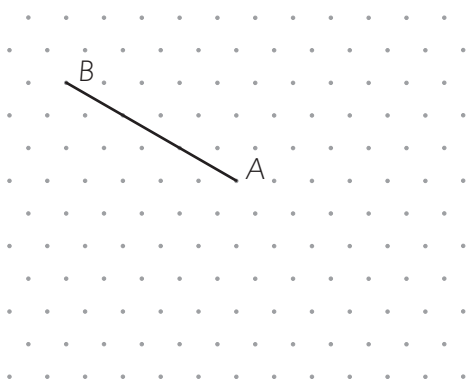
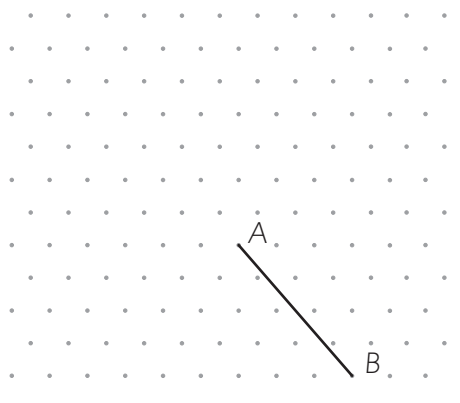
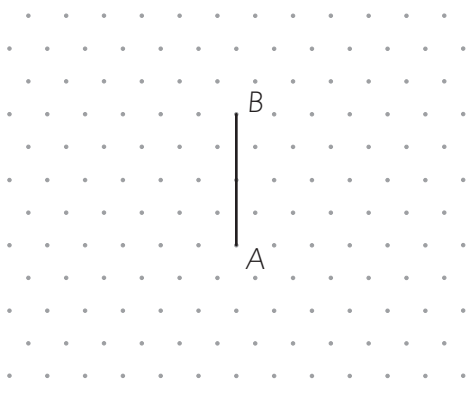
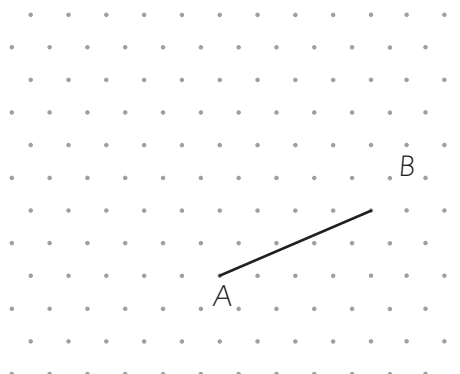
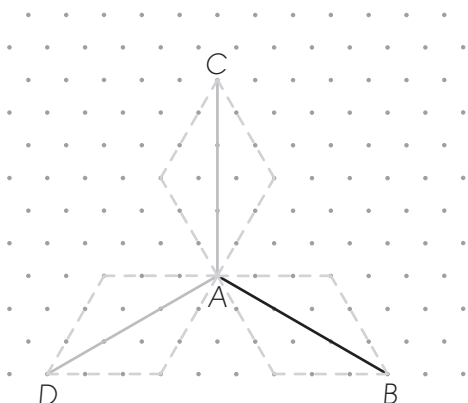

Punktowce dla klas 1–8 to nowatorskie ćwiczenia do rozwijania wyobraźni geometrycznej. Kupisz na www.księgarnia.gwo.pl



Punktowce

ćwiczenia rozgrzewkowe dla klas 4-6



5. Narysuj odcinek dwa razy dłuższy od narysowanego odcinka.

Przykładowe rozwiązanie:

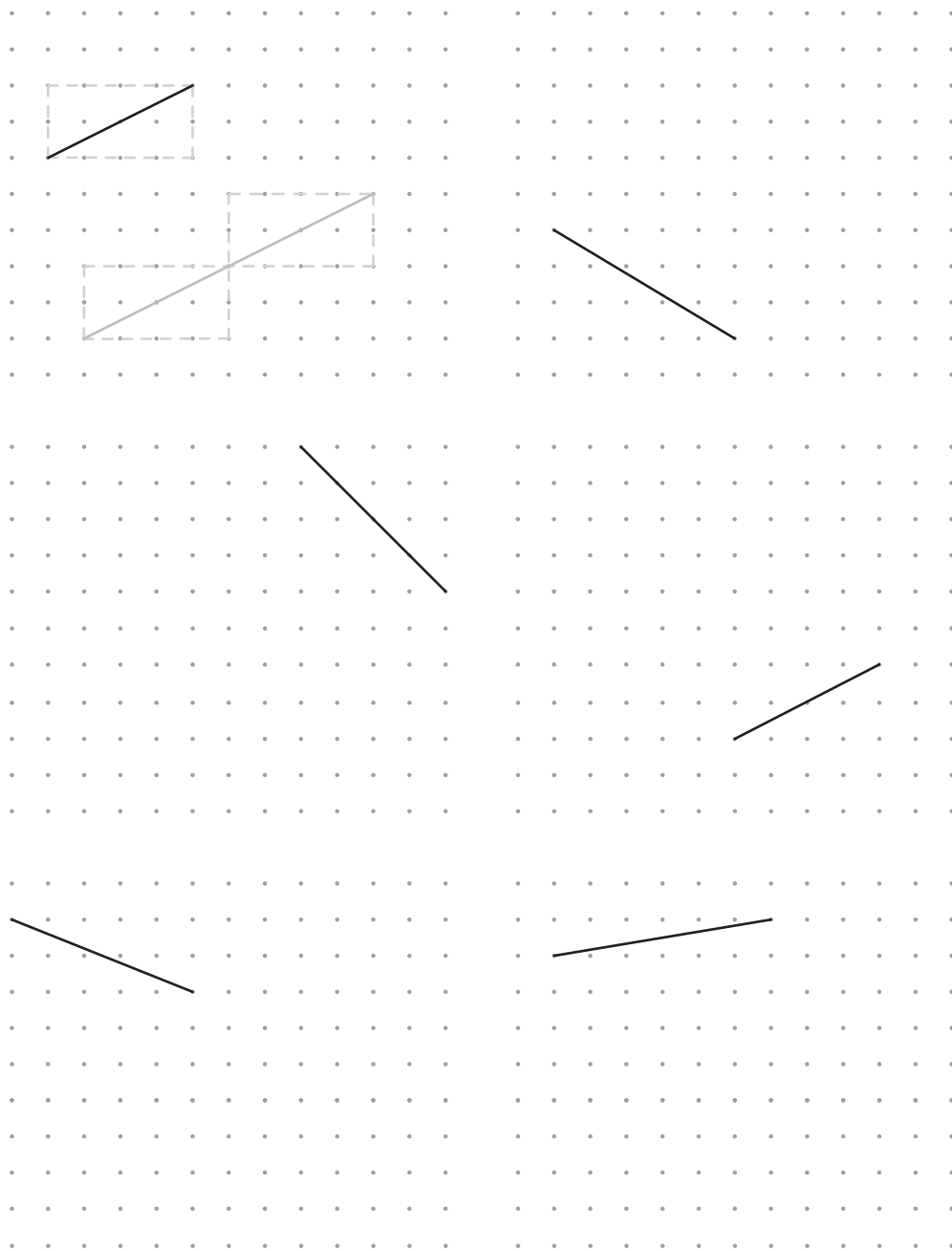

Punktowce dla klas 1–8 to nowatorskie ćwiczenia do rozwijania wyobraźni geometrycznej. Kupisz na www.ksiegarnia.gwo.pl

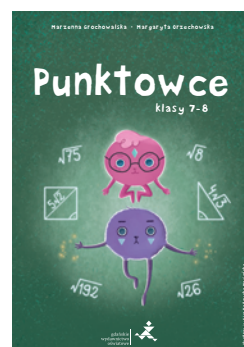

Punktowce

ćwiczenia rozgrzewkowe dla klas 4-6



6. Narysuj odcinek dwa razy dłuższy od narysowanego odcinka.

Przykładowe rozwiązanie:

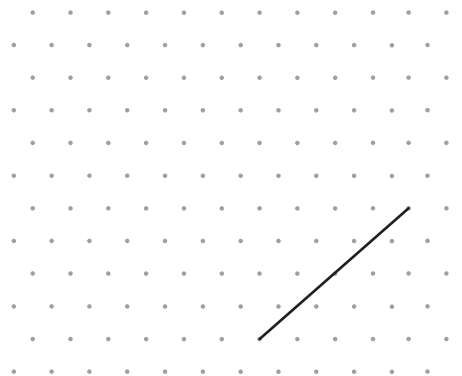
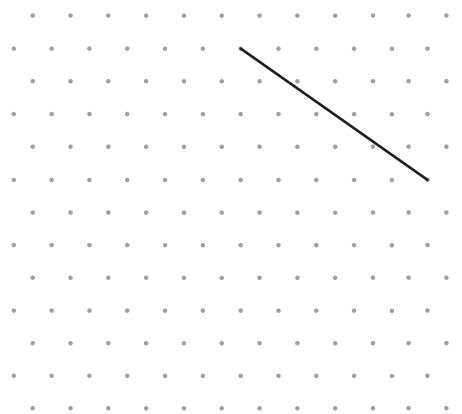
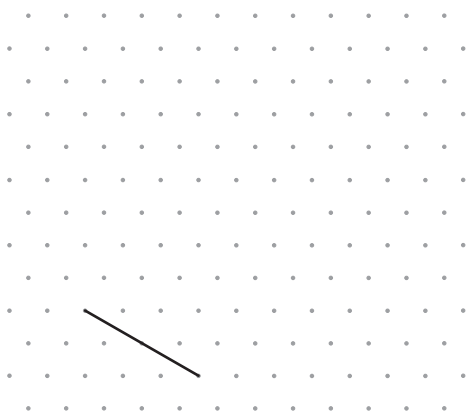
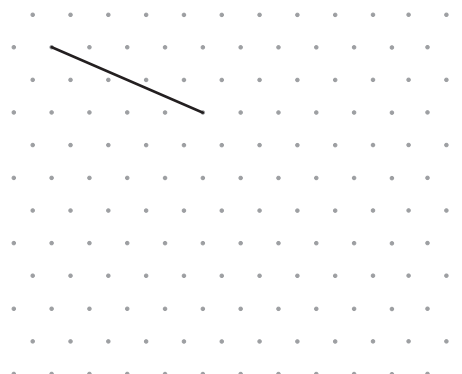
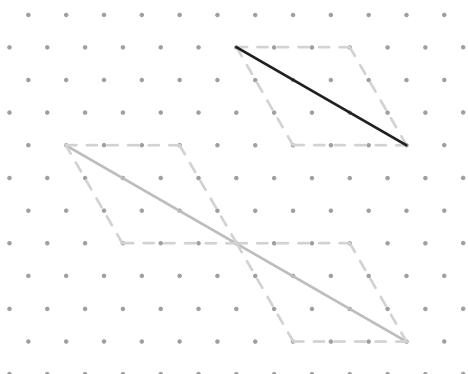

Punktowce dla klas 1–8 to nowatorskie ćwiczenia do rozwijania wyobraźni geometrycznej. Kupisz na www.księgarnia.gwo.pl



Punktowce

ćwiczenia rozgrzewkowe dla klas 4-6



7. Narysuj odcinek AC, który jest trzy razy dłuższy od odcinka AB.

Przykładowe rozwiązanie:

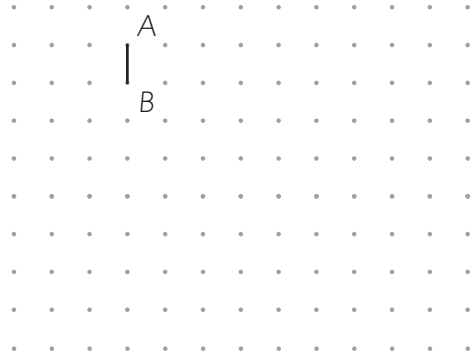
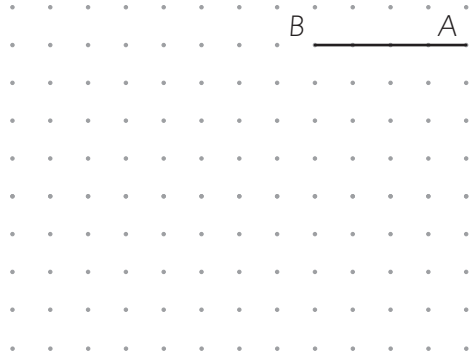
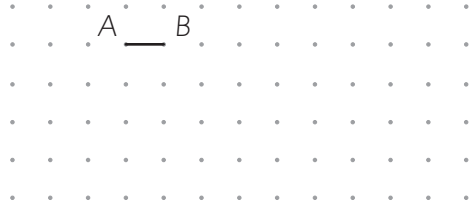
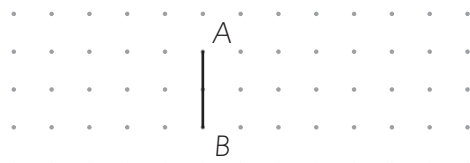

Punktowce dla klas 1–8 to nowatorskie ćwiczenia do rozwijania wyobraźni geometrycznej. Kupisz na www.księgarnia.gwo.pl



Punktowce

ćwiczenia rozgrzewkowe dla klas 4-6



8. Narysuj odcinek AC, który jest trzy razy dłuższy od odcinka AB.

Przykładowe rozwiązanie:

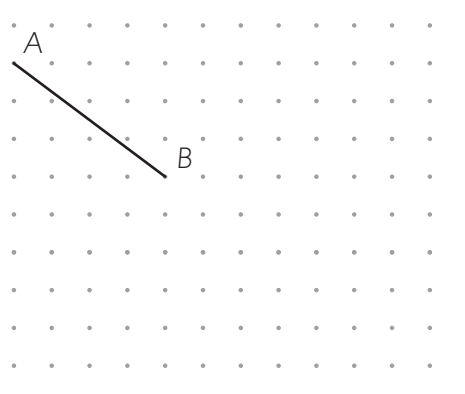
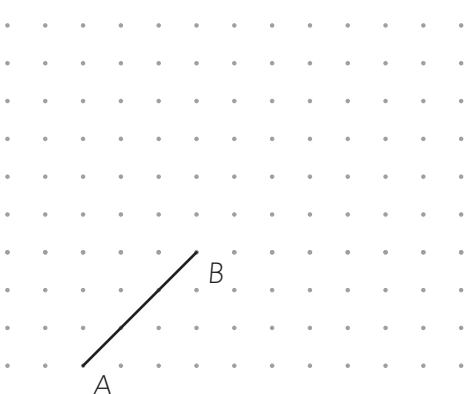
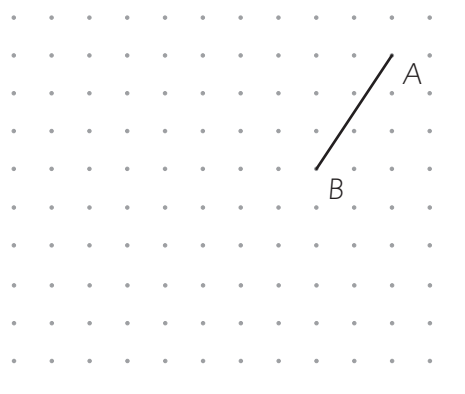
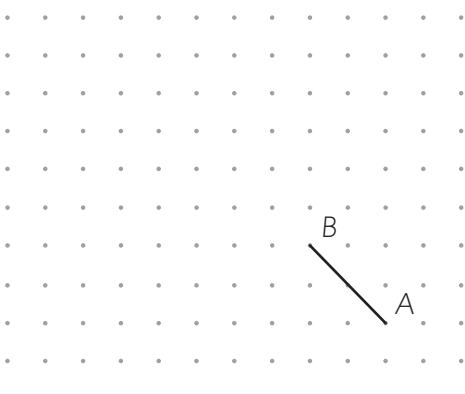
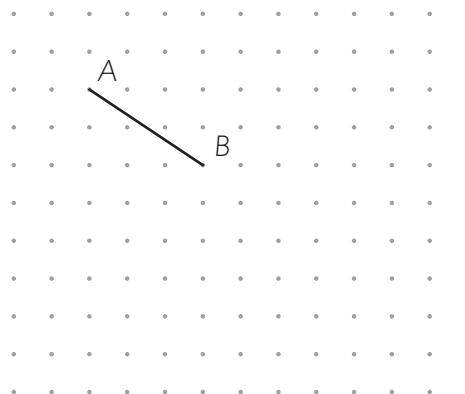
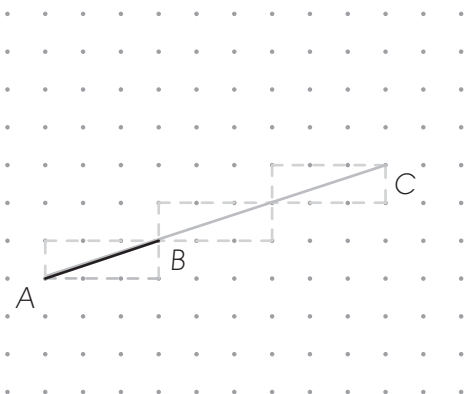

Punktowce dla klas 1-8 to nowatorskie ćwiczenia do rozwijania wyobraźni geometrycznej. Kupisz na www.ksiegarnia.gwo.pl

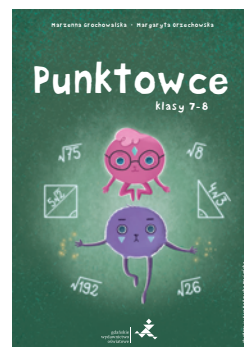

Punktowce

ćwiczenia rozgrzewkowe dla klas 4-6



9. Narysuj odcinek AC, który jest trzy razy dłuższy od odcinka AB.

Przykładowe rozwiązanie:

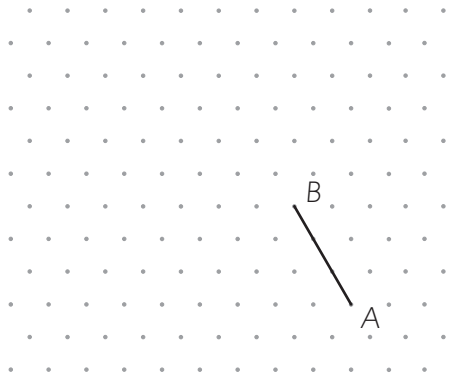
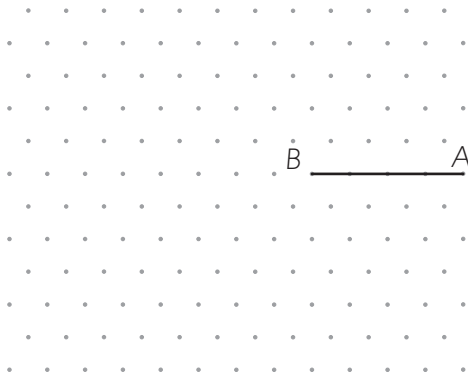
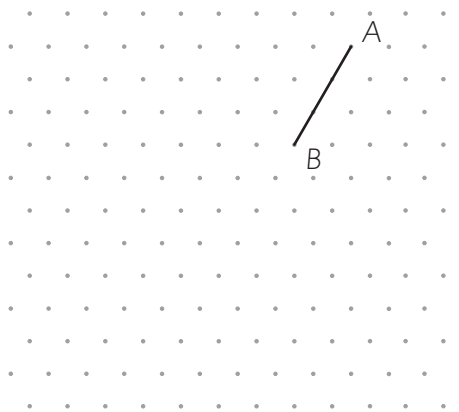
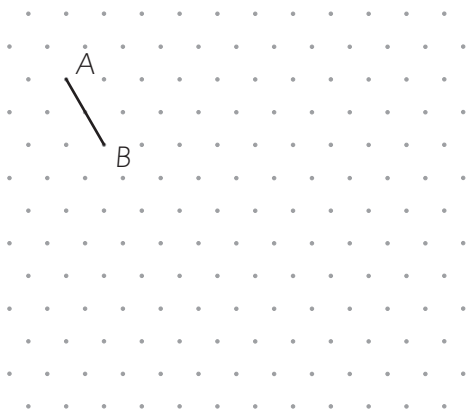
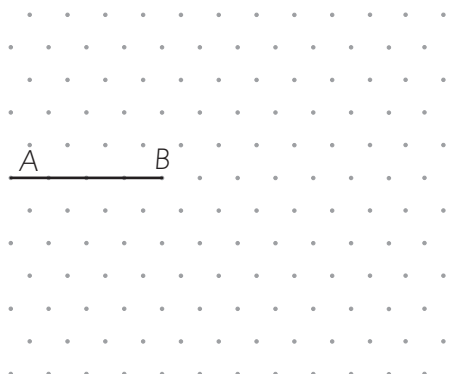
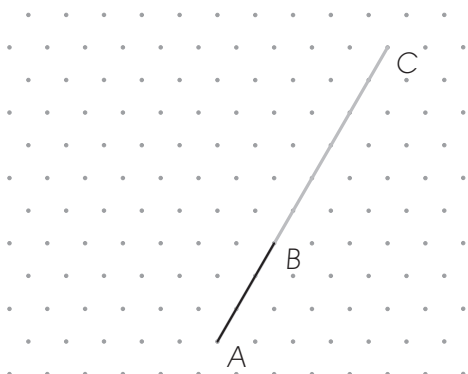

Punktowce dla klas 1–8 to nowatorskie ćwiczenia do rozwijania wyobraźni geometrycznej. Kupisz na www.księgarnia.gwo.pl



Punktowce

ćwiczenia rozgrzewkowe dla klas 4-6



10. Narysuj odcinek AC, który jest trzy razy dłuższy od odcinka AB.

Przykładowe rozwiązanie:

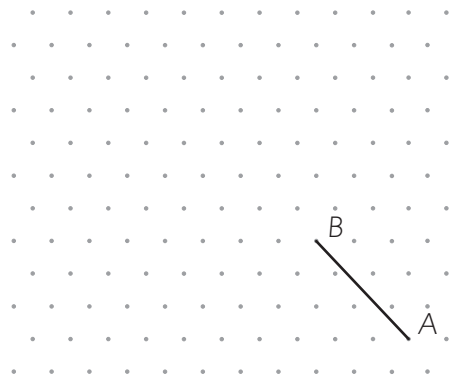
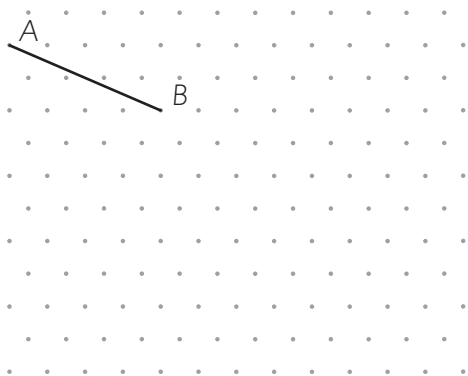
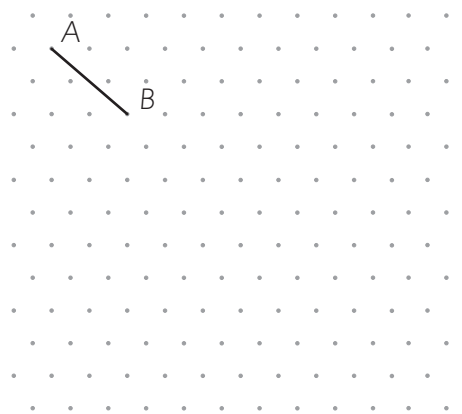
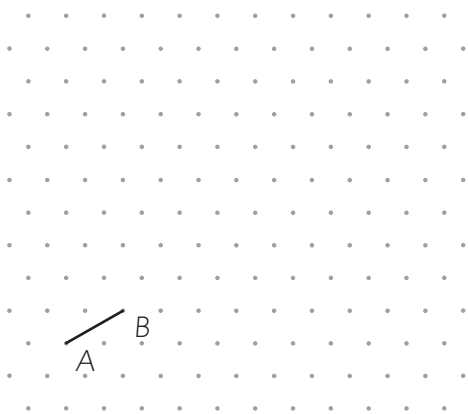
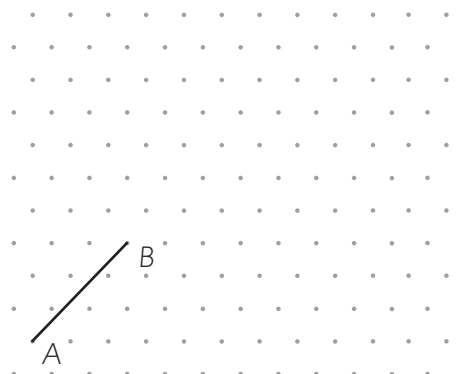
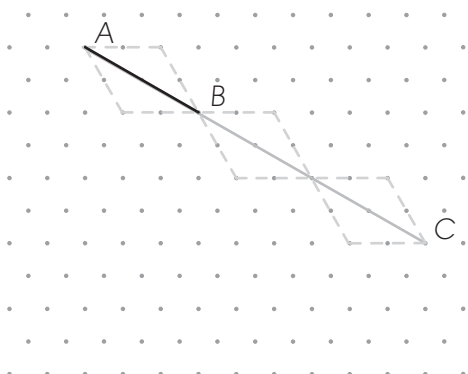

Punktowce dla klas 1–8 to nowatorskie ćwiczenia do rozwijania wyobraźni geometrycznej. Kupisz na www.ksiegarnia.gwo.pl

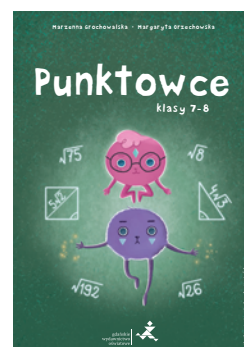

Punktowce

ćwiczenia rozgrzewkowe dla klas 4-6



11. Narysuj odcinek KL, który jest dwa razy krótszy od odcinka AB.

Przykładowe rozwiązanie:

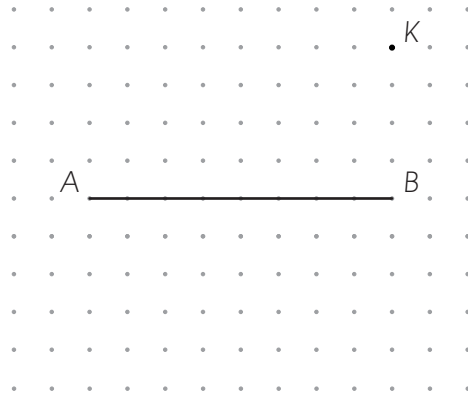
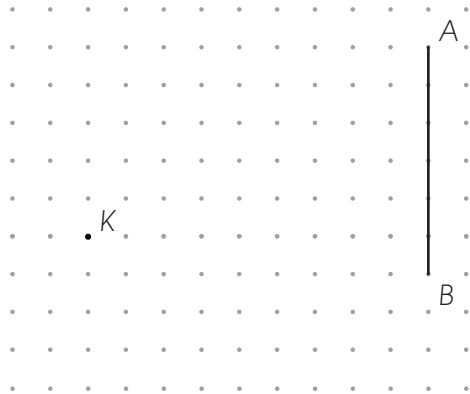
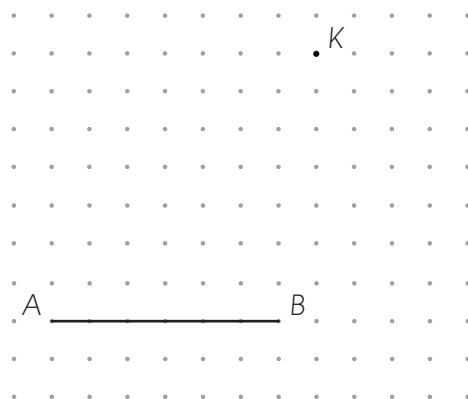
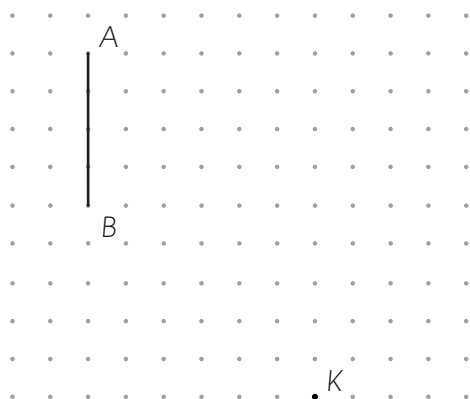
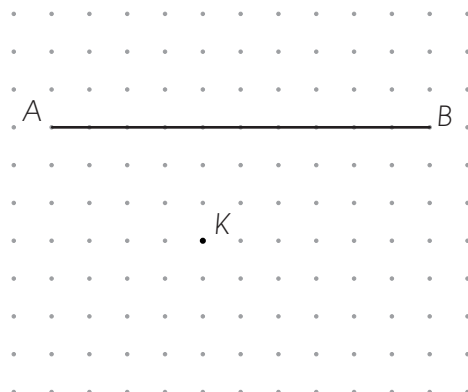
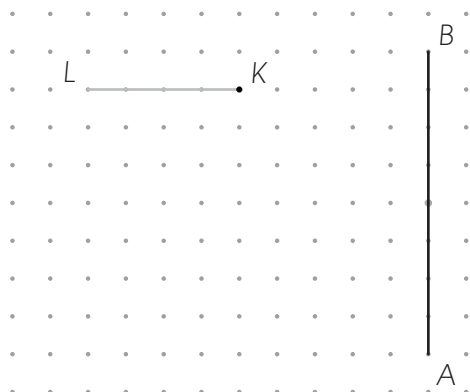

Punktowce dla klas 1–8 to nowatorskie ćwiczenia do rozwijania wyobraźni geometrycznej. Kupisz na www.ksiegarnia.gwo.pl



Punktowce

ćwiczenia rozgrzewkowe dla klas 4-6



12. Narysuj odcinek KL, który jest dwa razy krótszy od odcinka AB.

Przykładowe rozwiązanie:

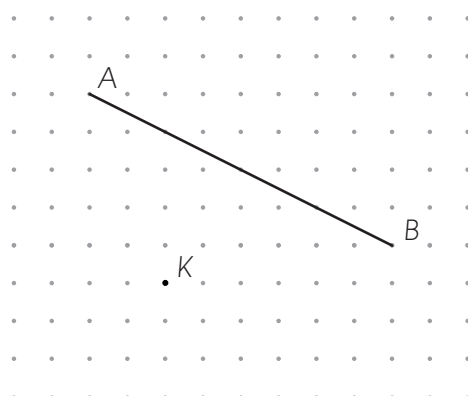
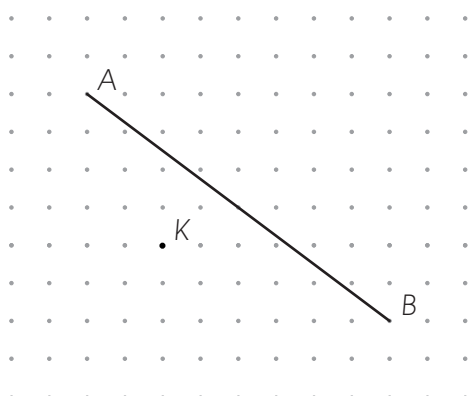
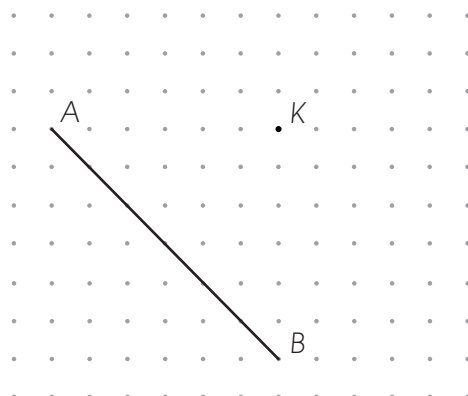
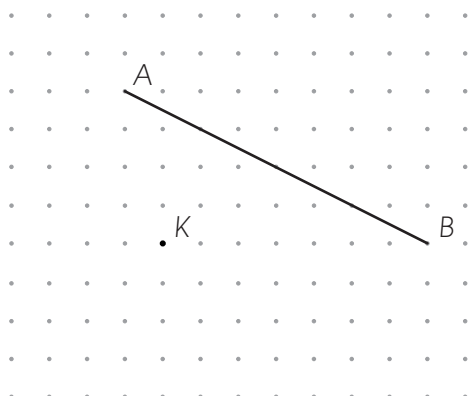
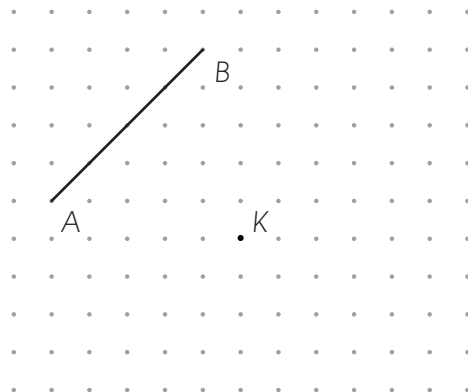
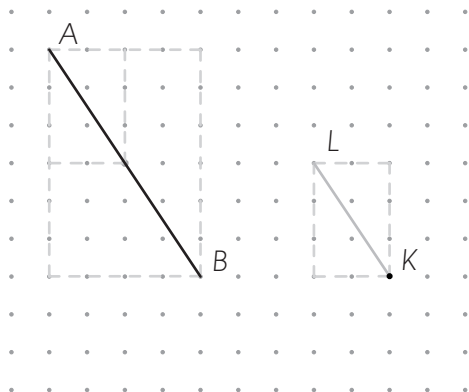

Punktowce dla klas 1–8 to nowatorskie ćwiczenia do rozwijania wyobraźni geometrycznej. Kupisz na www.ksiegarnia.gwo.pl



Punktowce

ćwiczenia rozgrzewkowe dla klas 4-6



13. Narysuj odcinek KL, który jest dwa razy krótszy od odcinka AB.

Przykładowe rozwiązanie:

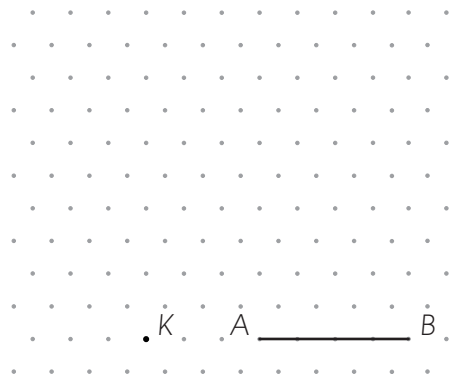
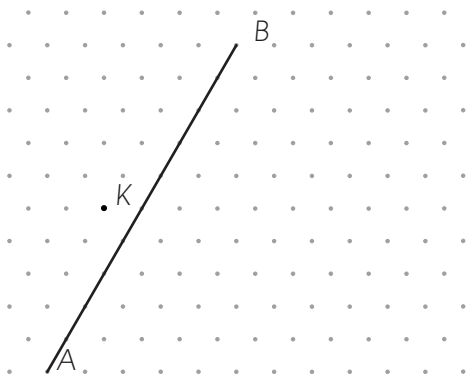
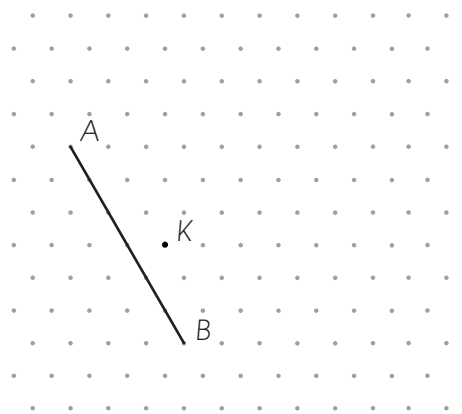
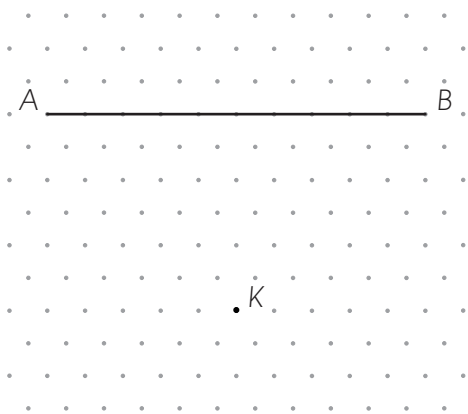
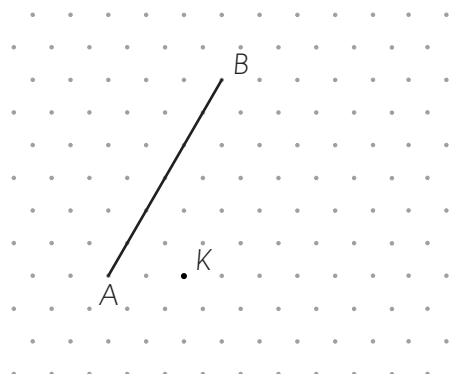
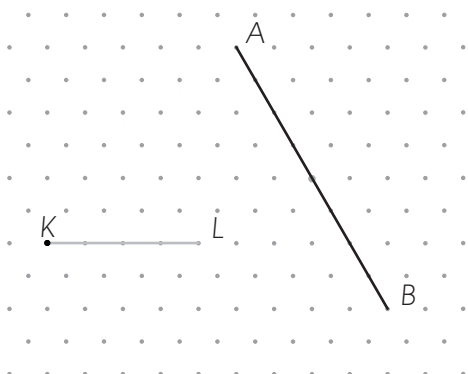

Punktowce dla klas 1–8 to nowatorskie ćwiczenia do rozwijania wyobraźni geometrycznej. Kupisz na www.ksiegarnia.gwo.pl



Punktowce

ćwiczenia rozgrzewkowe dla klas 4-6



14. Narysuj odcinek KL, który jest dwa razy krótszy od odcinka AB.

Przykładowe rozwiązanie:

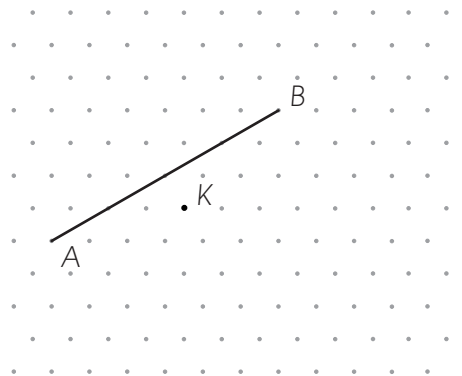
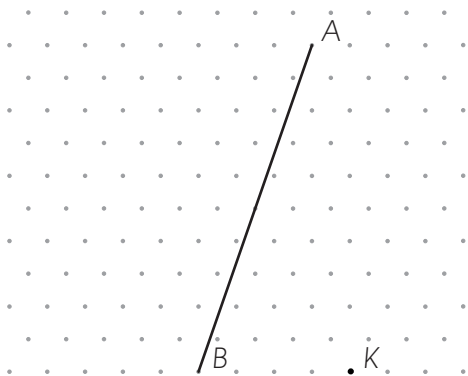
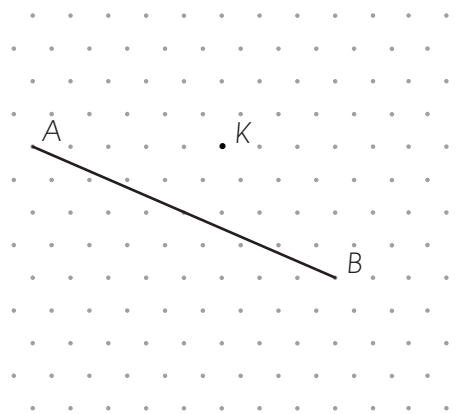
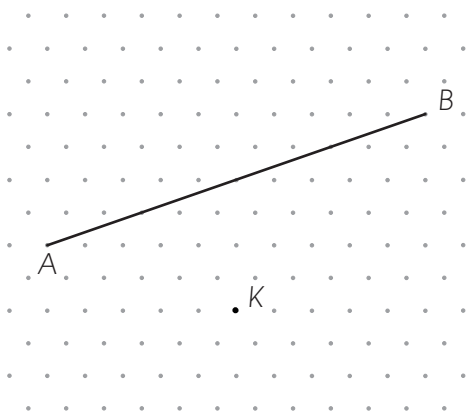
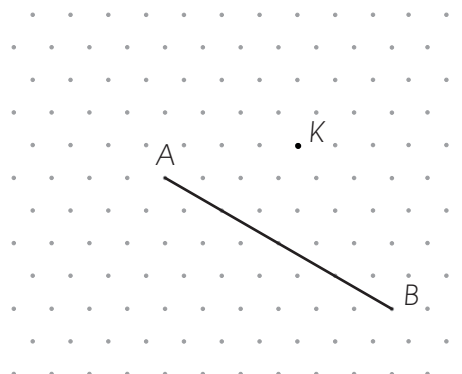
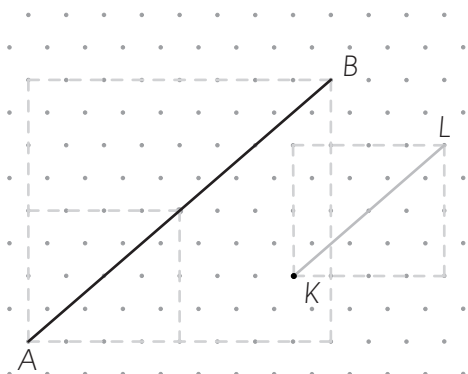

Punktowce dla klas 1–8 to nowatorskie ćwiczenia do rozwijania wyobraźni geometrycznej. Kupisz na www.ksiegarnia.gwo.pl



Punktowce

ćwiczenia rozgrzewkowe dla klas 4-6



15. Narysuj odcinek RS , który jest trzy razy krótszy od odcinka AB .

Przykładowe rozwiązanie:

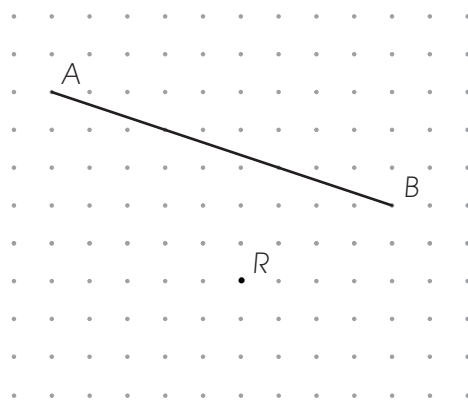
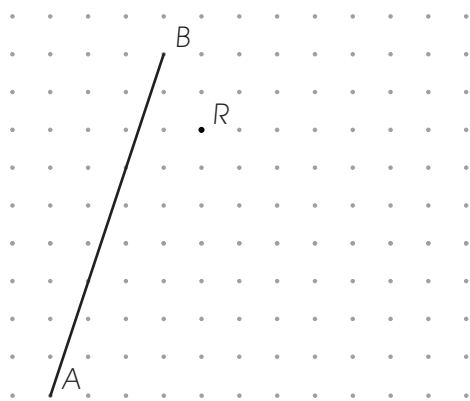
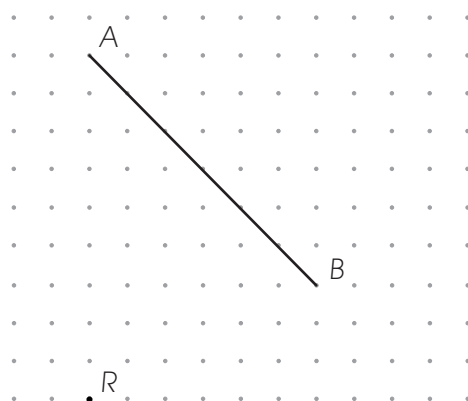
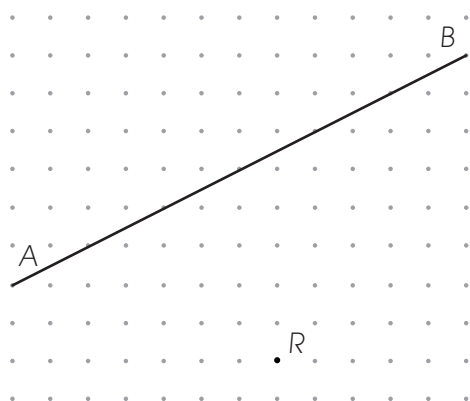
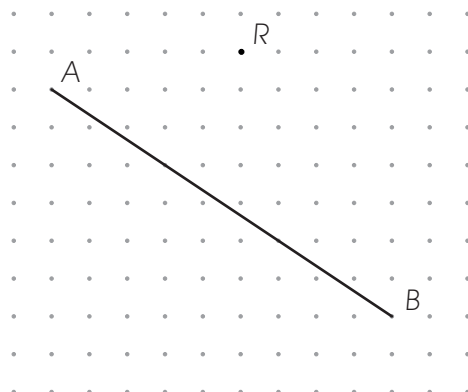
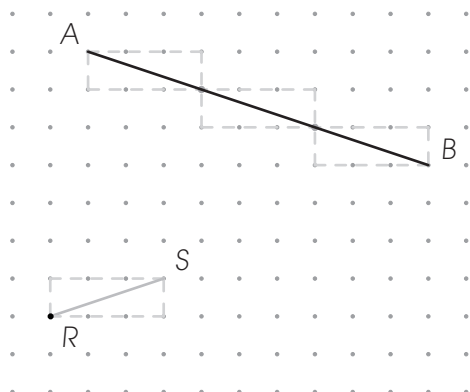

Punktowce dla klas 1–8 to nowatorskie ćwiczenia do rozwijania wyobraźni geometrycznej. Kupisz na www.księgarnia.gwo.pl



Punktowce

ćwiczenia rozgrzewkowe dla klas 4-6



16. Narysuj odcinek RS , który jest trzy razy krótszy od odcinka AB .

Przykładowe rozwiązanie:

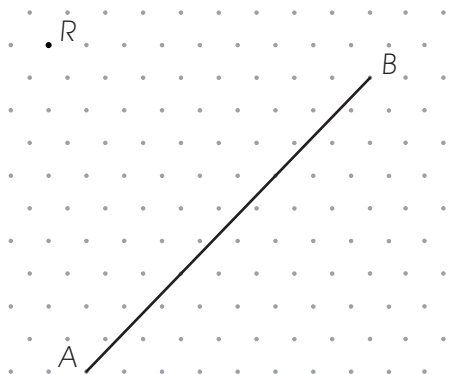
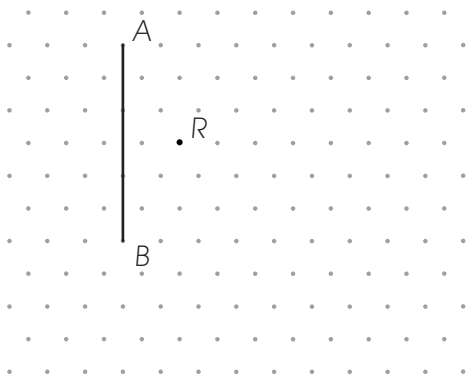
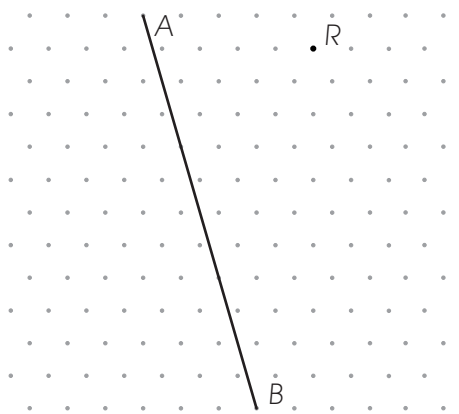
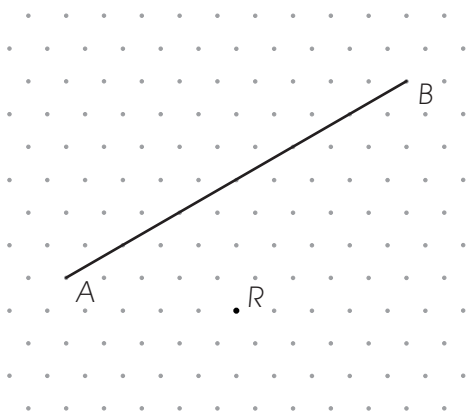
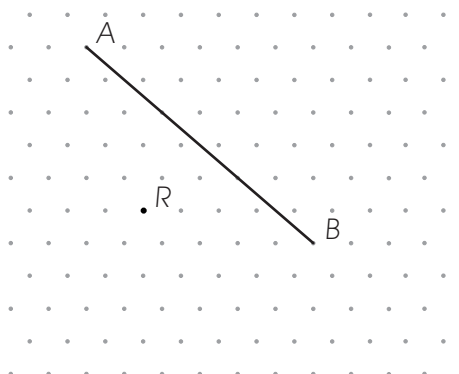
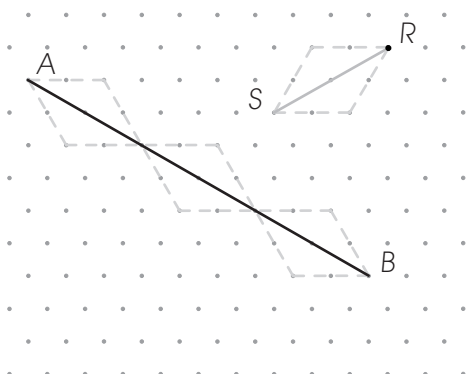

Punktowce dla klas 1–8 to nowatorskie ćwiczenia do rozwijania wyobraźni geometrycznej. Kupisz na www.ksiegarnia.gwo.pl

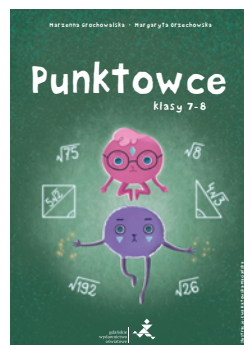

Punktowce

ćwiczenia rozgrzewkowe dla klas 4-6



17. Narysuj odcinek KL równoległy do odcinka AB.

Przykładowe rozwiązanie:

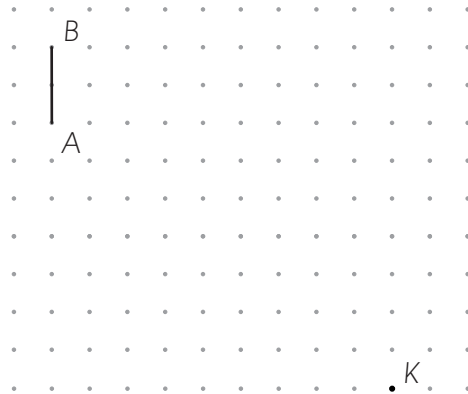
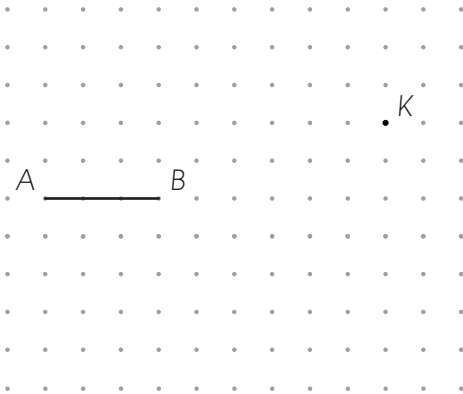
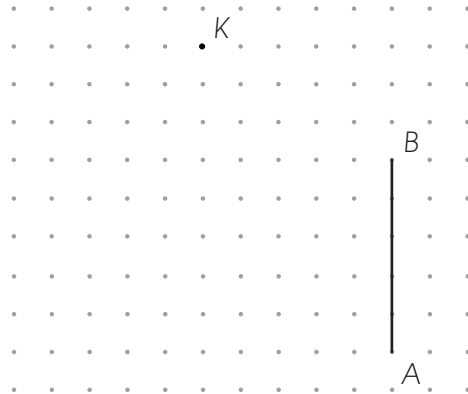
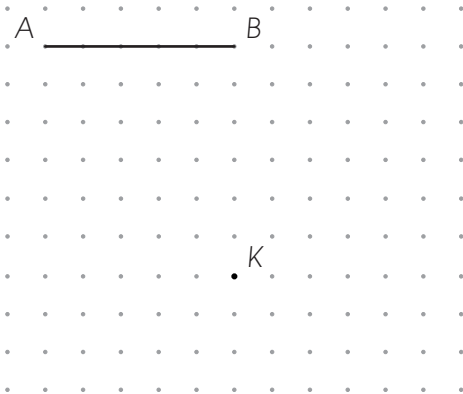
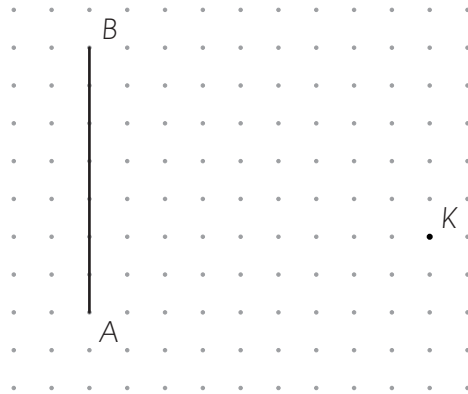
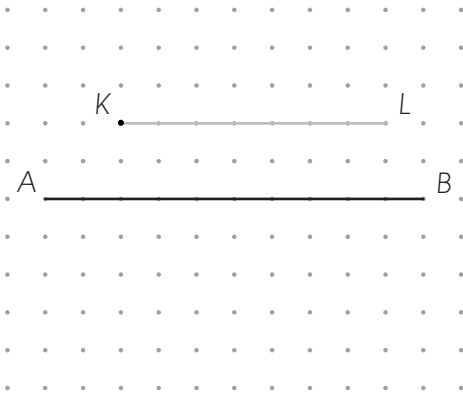

Punktowce dla klas 1–8 to nowatorskie ćwiczenia do rozwijania wyobraźni geometrycznej. Kupisz na www.ksiegarnia.gwo.pl

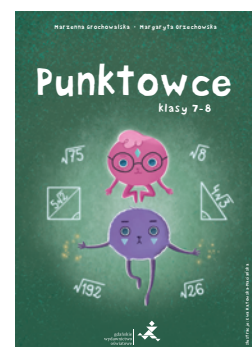

Punktowce

ćwiczenia rozgrzewkowe dla klas 4-6



18. Narysuj odcinek równoległy do danego odcinka.

Przykładowe rozwiązanie:

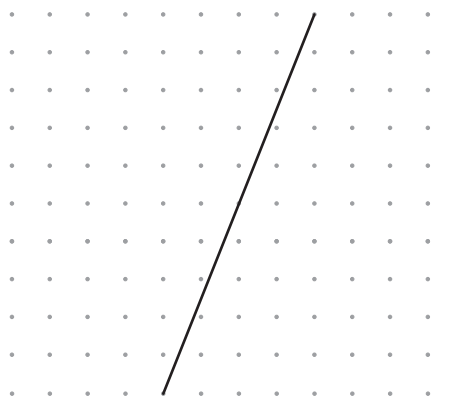
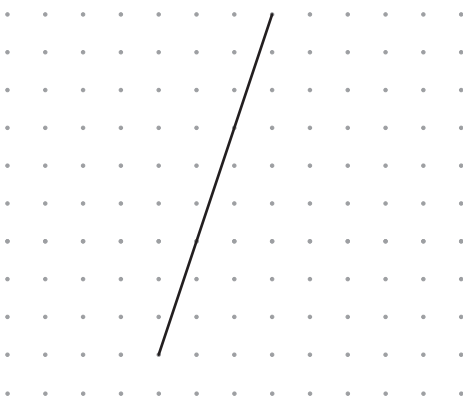
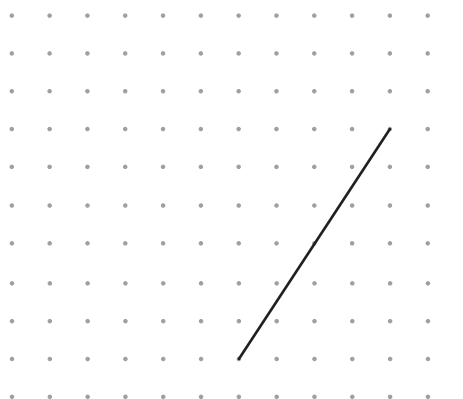
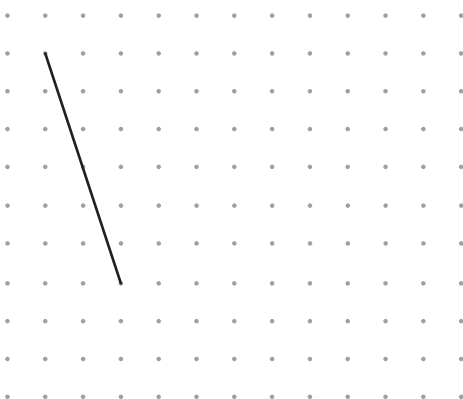
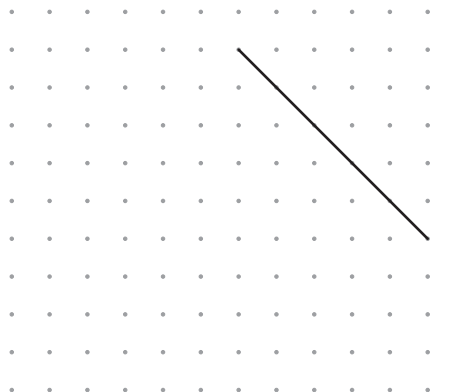
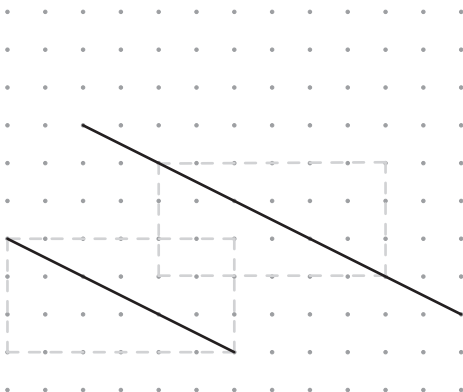

Punktowce dla klas 1–8 to nowatorskie ćwiczenia do rozwijania wyobraźni geometrycznej. Kupisz na www.księgarnia.gwo.pl

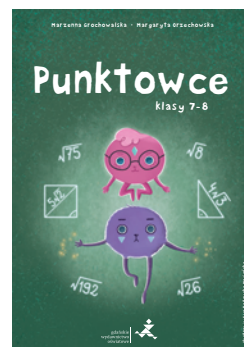

Punktowce

ćwiczenia rozgrzewkowe dla klas 4-6



19. Narysuj odcinek RS równoległy do odcinka AB .

Przykładowe rozwiązanie:

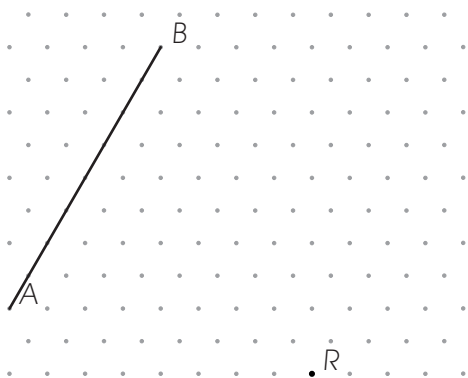
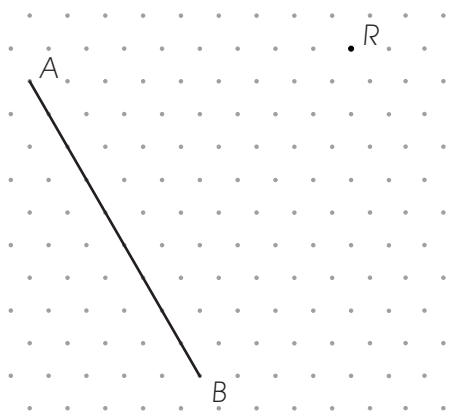
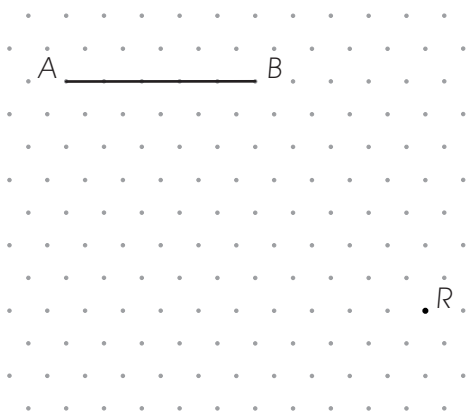
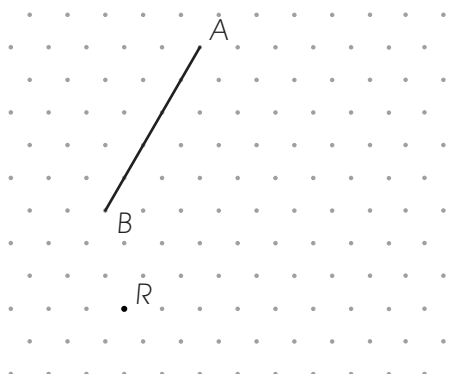
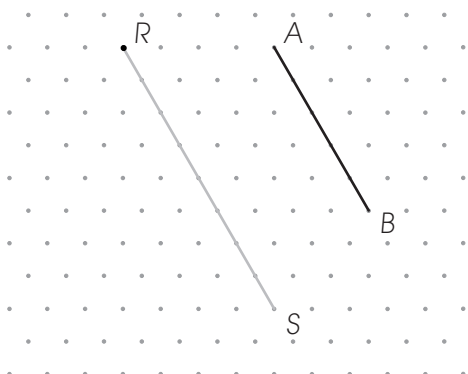

Punktowce dla klas 1–8 to nowatorskie ćwiczenia do rozwijania wyobraźni geometrycznej. Kupisz na www.księgarnia.gwo.pl

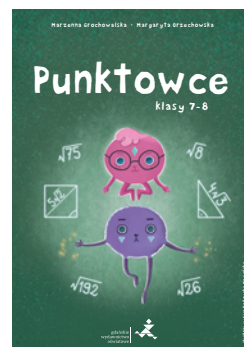

Punktowce

ćwiczenia rozgrzewkowe dla klas 4-6



20. Narysuj odcinek równoległy do danego odcinka.

Przykładowe rozwiązanie:

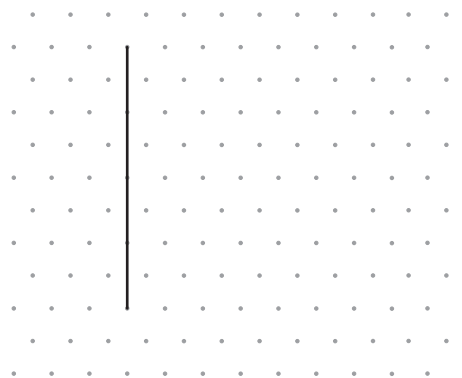
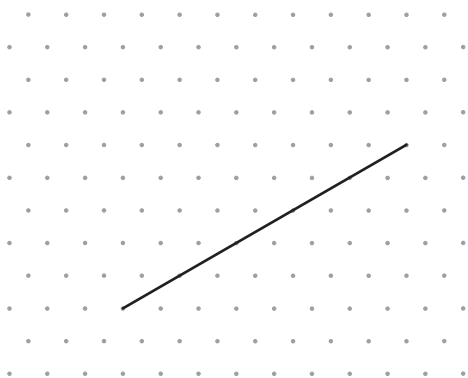
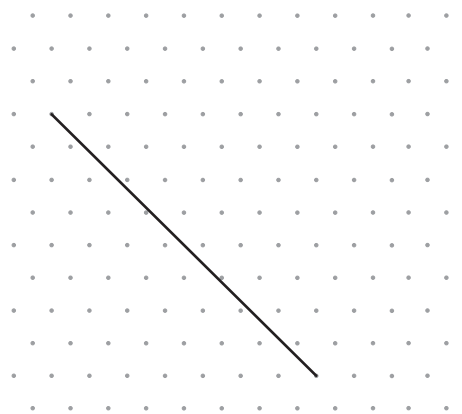
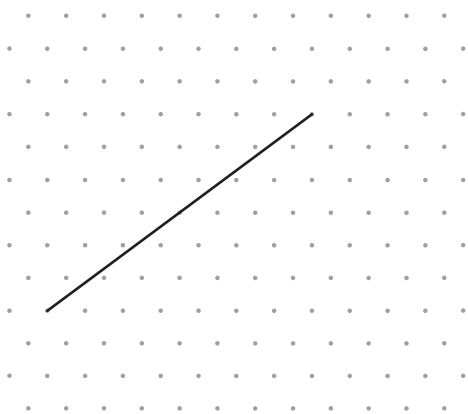
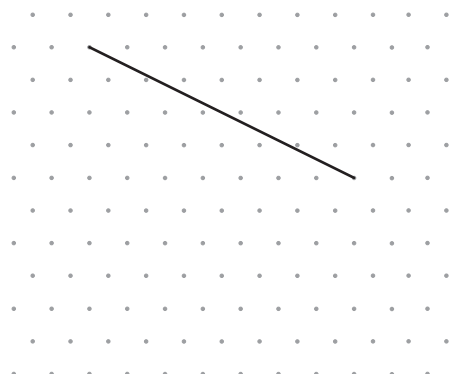
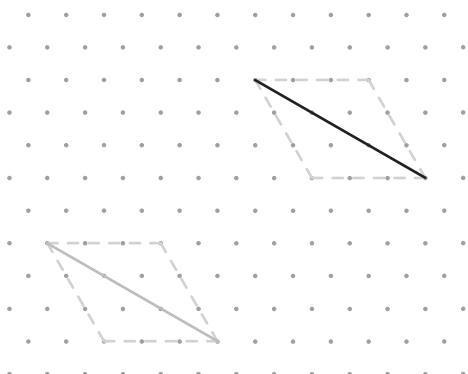

Punktowce dla klas 1–8 to nowatorskie ćwiczenia do rozwijania wyobraźni geometrycznej. Kupisz na www.ksiegarnia.gwo.pl

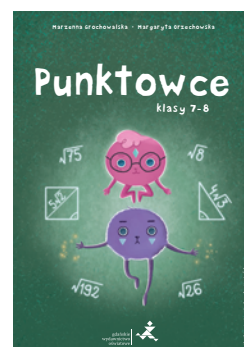

Punktowce

ćwiczenia rozgrzewkowe dla klas 4-6



21. Narysuj odcinek równoległy do danego odcinka, przechodzący przez punkt K.

Przykładowe rozwiązanie:

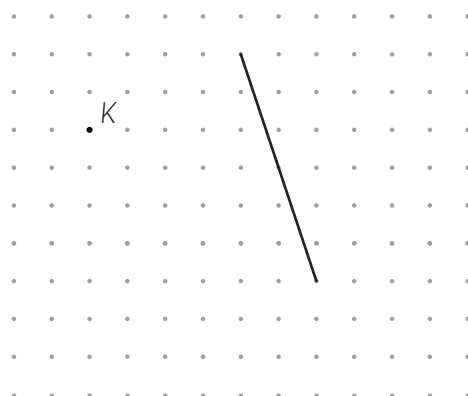
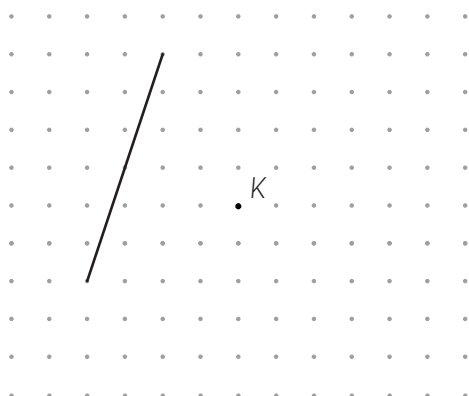
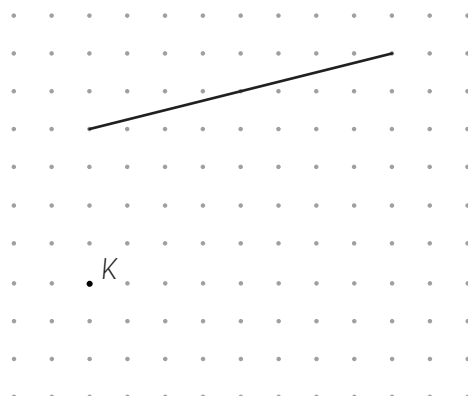
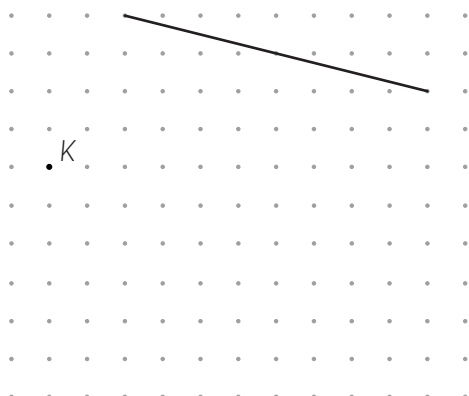
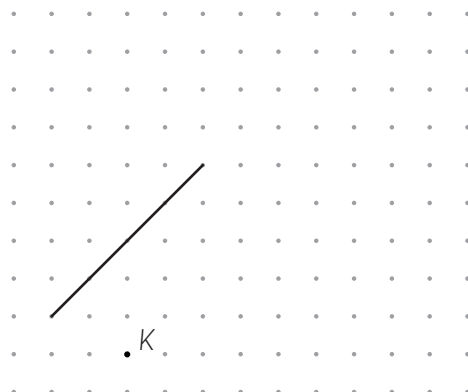
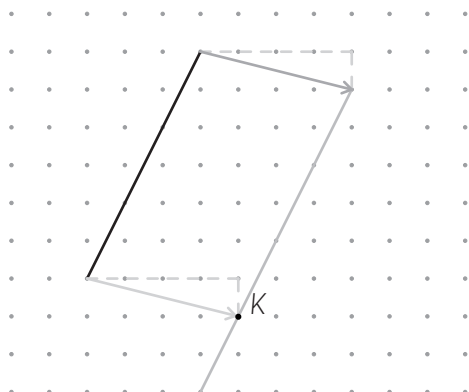

Punktowce dla klas 1-8 to nowatorskie ćwiczenia do rozwijania wyobraźni geometrycznej. Kupisz na www.ksiegarnia.gwo.pl



Punktowce

ćwiczenia rozgrzewkowe dla klas 4-6



22. Narysuj odcinek równoległy do danego odcinka, przechodzący przez punkt K.

Przykładowe rozwiązanie:

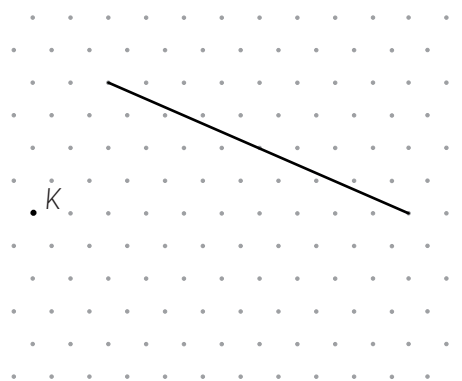
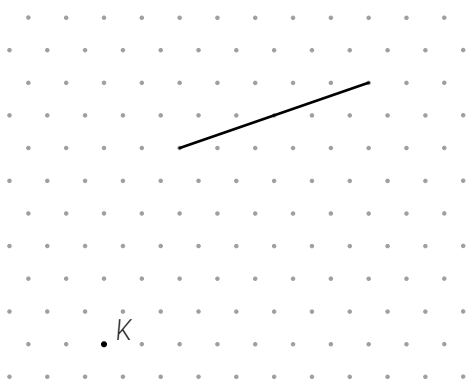
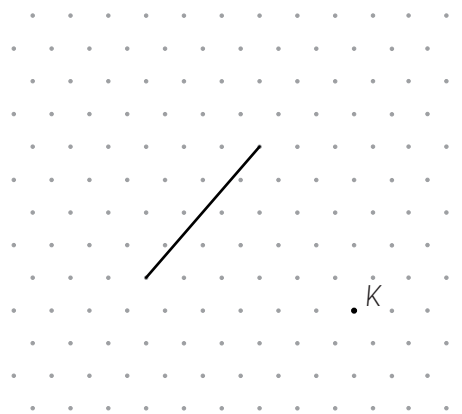
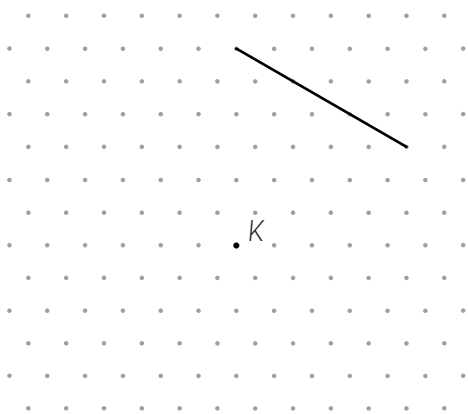
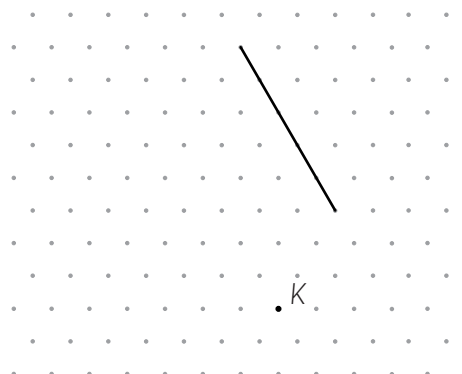
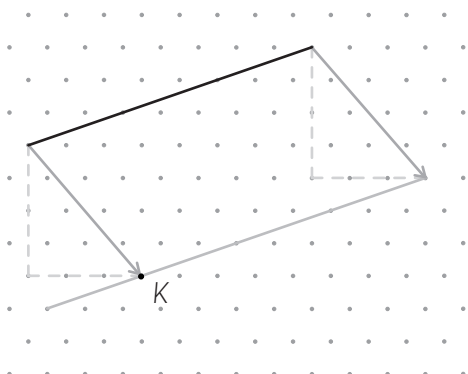

Punktowce dla klas 1–8 to nowatorskie ćwiczenia do rozwijania wyobraźni geometrycznej. Kupisz na www.księgarnia.gwo.pl



Punktowce

ćwiczenia rozgrzewkowe dla klas 4-6



23. Narysuj odcinek równoległy do danego odcinka i dwa razy od niego dłuższy.

Przykładowe rozwiązanie:

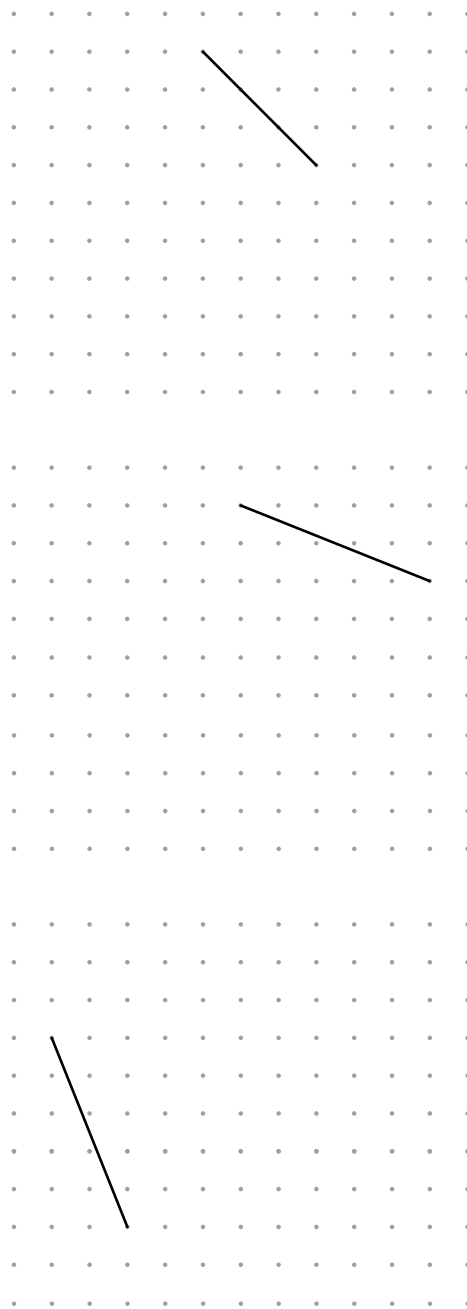
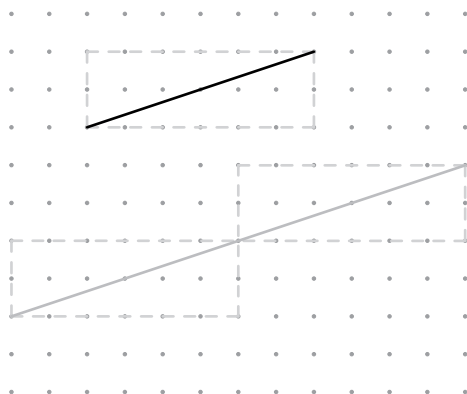

Punktowce dla klas 1–8 to nowatorskie ćwiczenia do rozwijania wyobraźni geometrycznej. Kupisz na www.księgarnia.gwo.pl

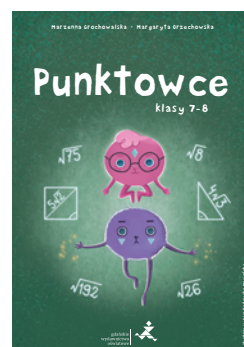

Punktowce

ćwiczenia rozgrzewkowe dla klas 4-6



24. Narysuj odcinek równoległy do danego odcinka i dwa razy od niego dłuższy.

Przykładowe rozwiązanie:

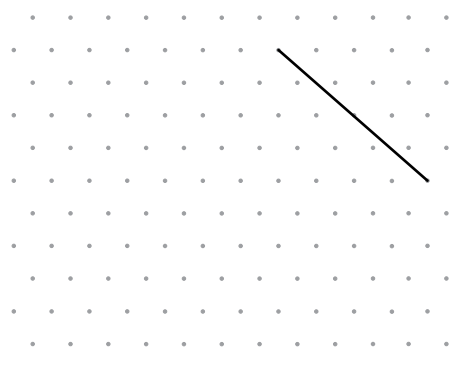
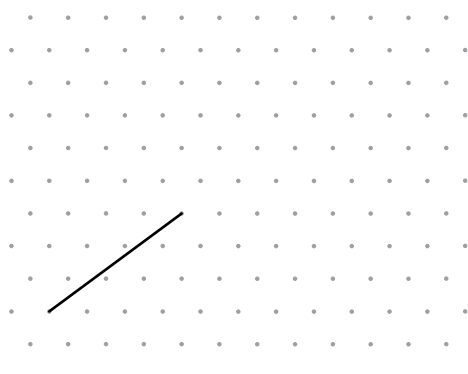
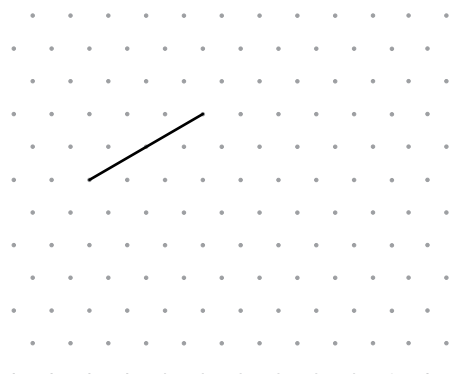
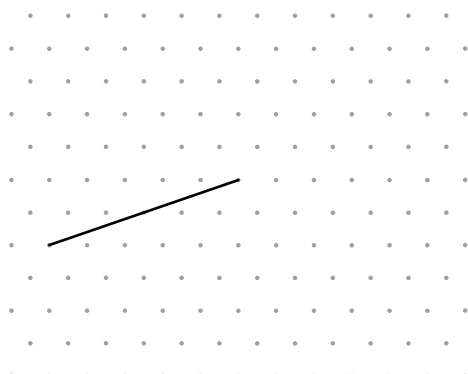
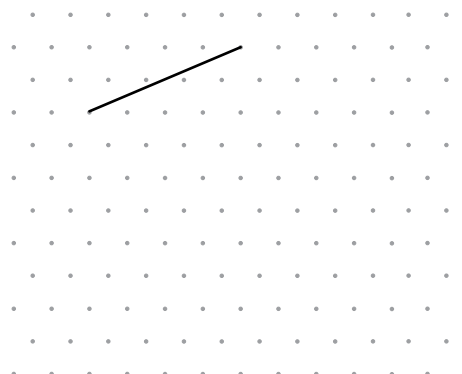
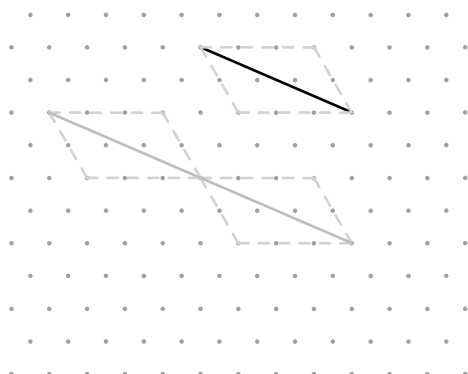

Punktowce dla klas 1–8 to nowatorskie ćwiczenia do rozwijania wyobraźni geometrycznej. Kupisz na www.ksiegarnia.gwo.pl



Punktowce

ćwiczenia rozgrzewkowe dla klas 4-6



25. Narysuj odcinek równoległy do danego odcinka i dwa razy od niego krótszy.

Przykładowe rozwiązanie:

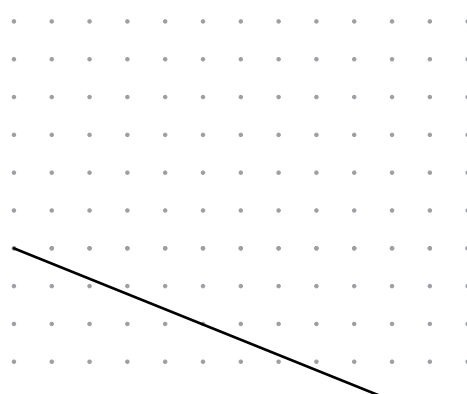
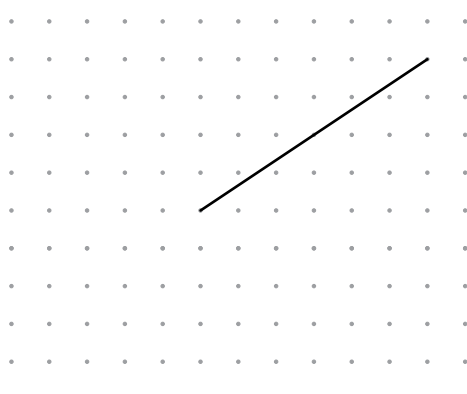
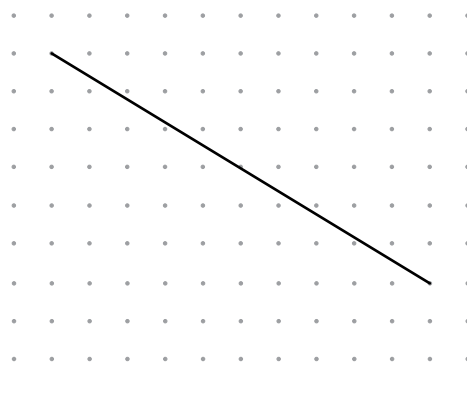
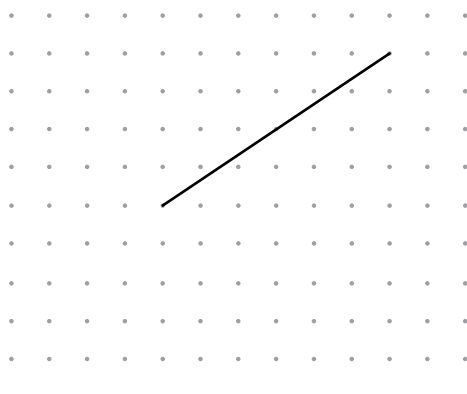
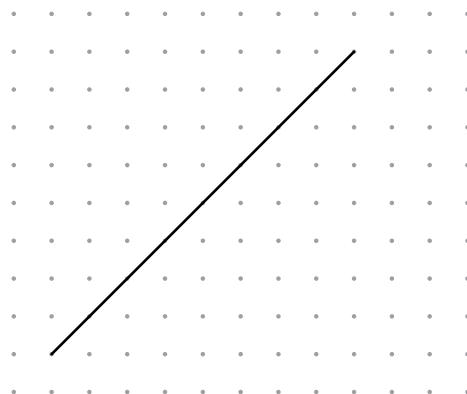
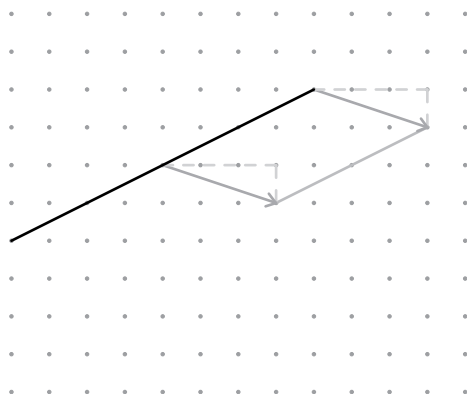

Punktowce dla klas 1–8 to nowatorskie ćwiczenia do rozwijania wyobraźni geometrycznej. Kupisz na www.księgarnia.gwo.pl



Punktowce

ćwiczenia rozgrzewkowe dla klas 4-6



26. Narysuj odcinek równoległy do danego odcinka i dwa razy od niego krótszy.

Przykładowe rozwiązanie:

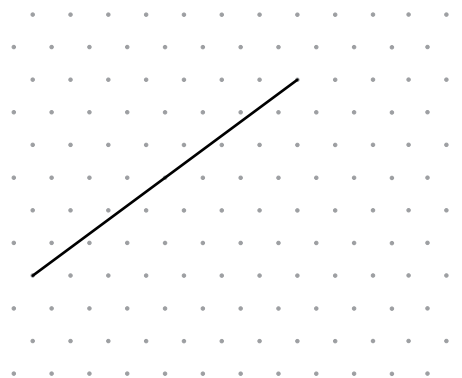
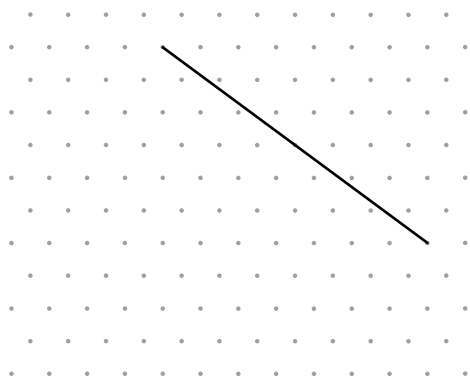
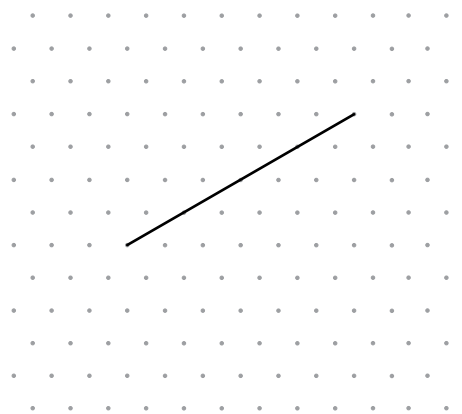
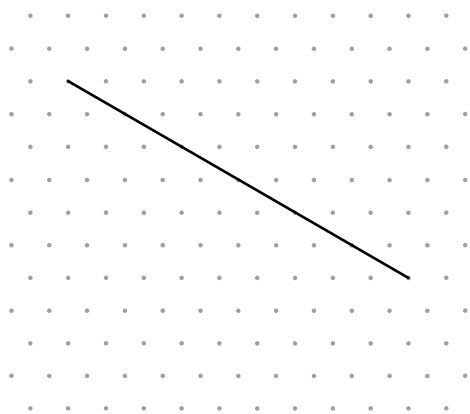
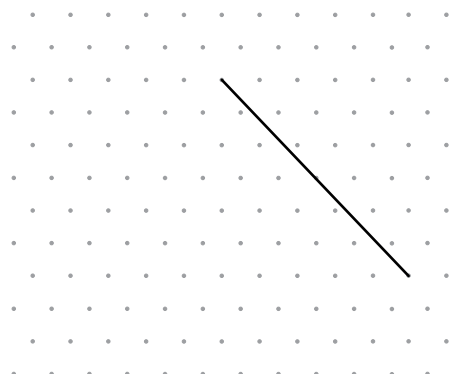
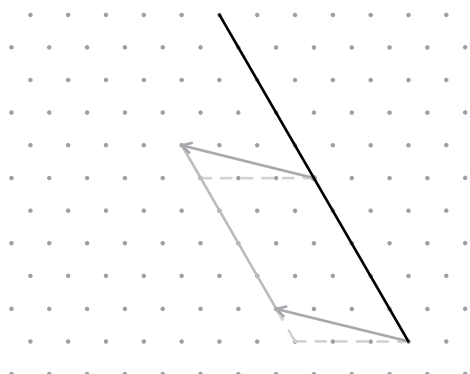

Punktowce dla klas 1–8 to nowatorskie ćwiczenia do rozwijania wyobraźni geometrycznej. Kupisz na www.księgarnia.gwo.pl



Punktowce

ćwiczenia rozgrzewkowe dla klas 4-6



27. Narysuj tamagę KLMN, której kolejne odcinki są równoległe do odcinków tamanej ABCD i mają taką samą długość jak odcinki tamanej ABCD.

Przykładowe rozwiązanie:

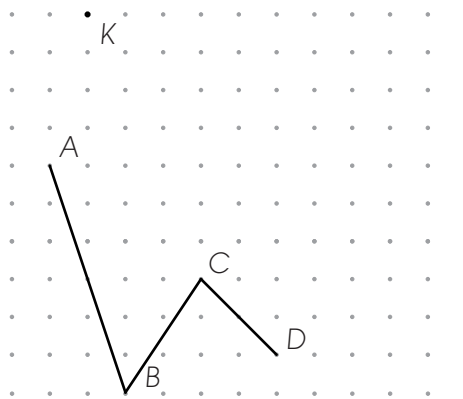
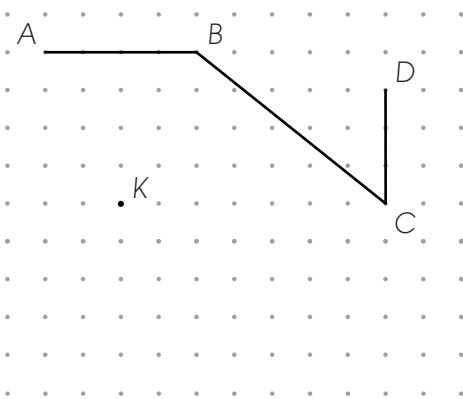
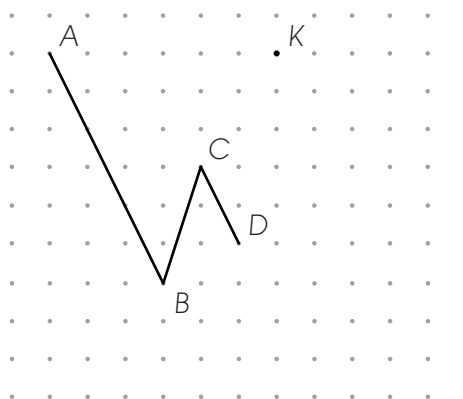
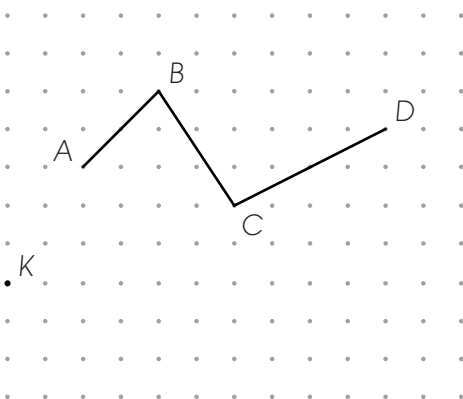
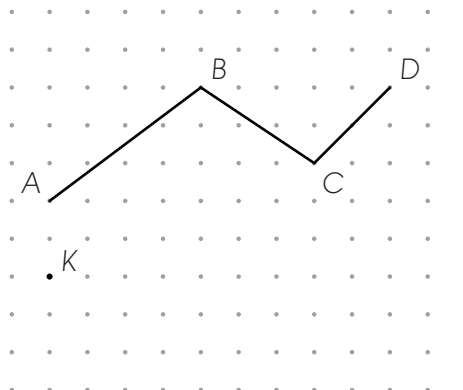
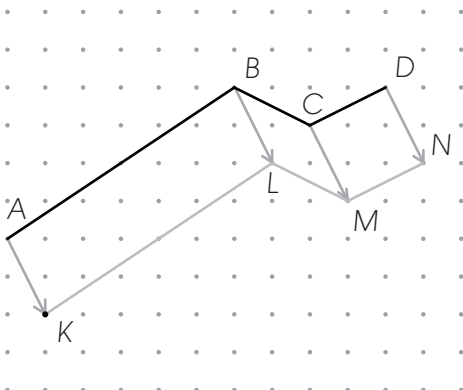

Punktowce dla klas 1-8 to nowatorskie ćwiczenia do rozwijania wyobraźni geometrycznej. Kupisz na www.ksiegarnia.gwo.pl



Punktowce

ćwiczenia rozgrzewkowe dla klas 4-6



28. Narysuj tamagę KLMN, której kolejne odcinki są równoległe do odcinków tamanej ABCD i mają taką samą długość jak odcinki tamanej ABCD.

Przykładowe rozwiązanie:

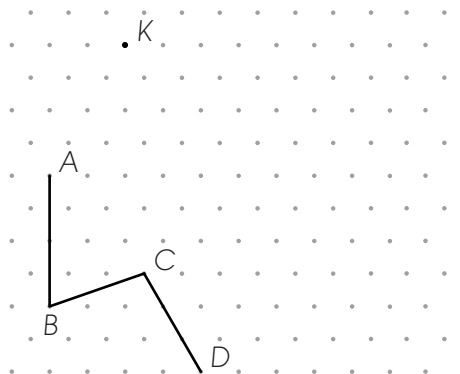
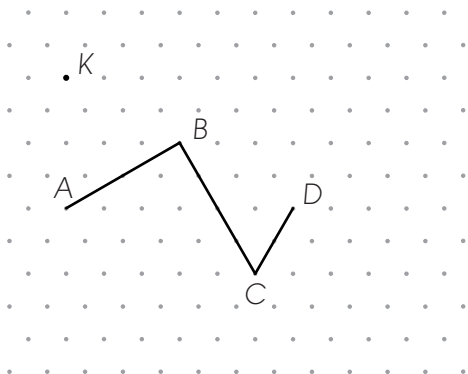
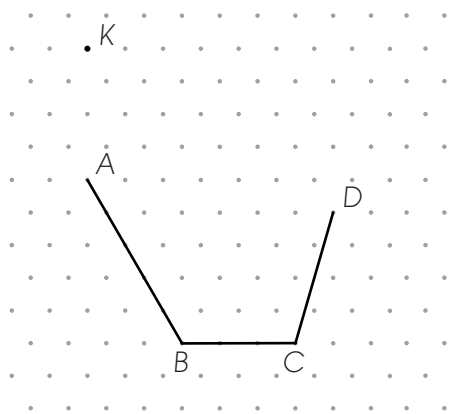
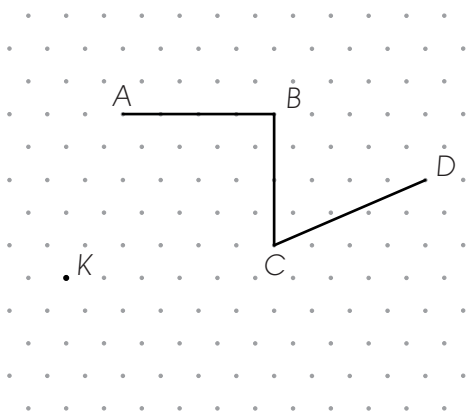
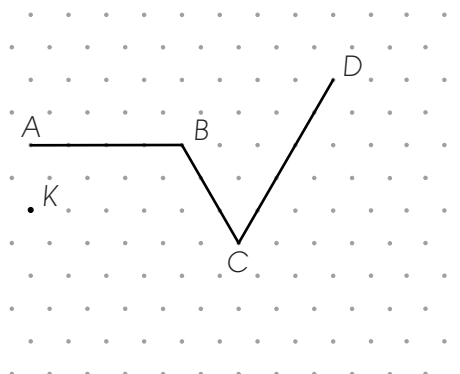
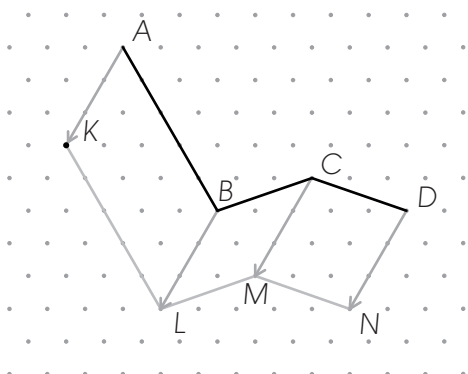

Punktowce dla klas 1-8 to nowatorskie ćwiczenia do rozwijania wyobraźni geometrycznej. Kupisz na www.księgarnia.gwo.pl

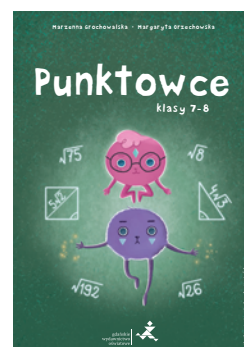

Punktowce

ćwiczenia rozgrzewkowe dla klas 4-6



29. Narysuj odcinek KL prostopadły do odcinka AB .

Przykładowe rozwiązanie:

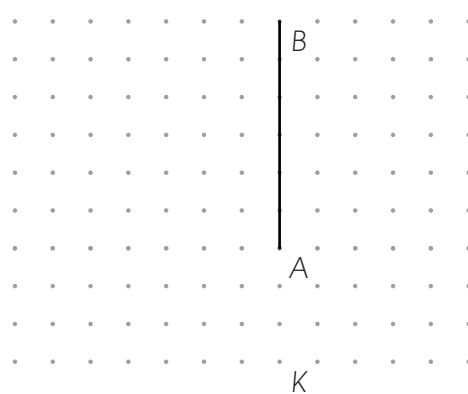
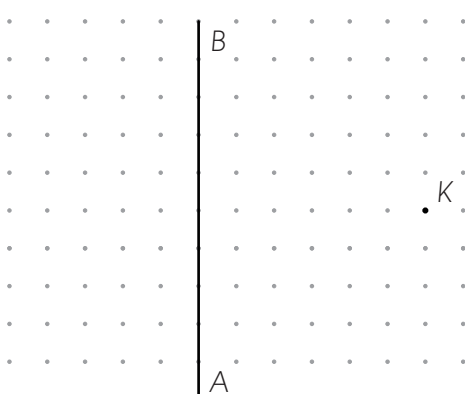
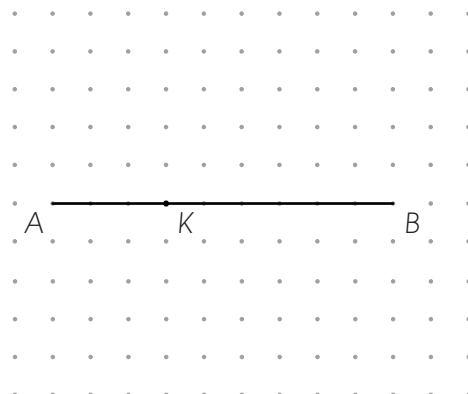
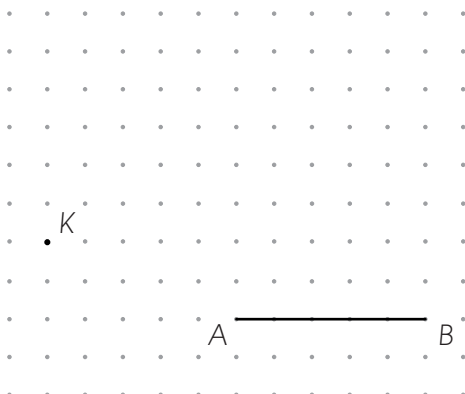
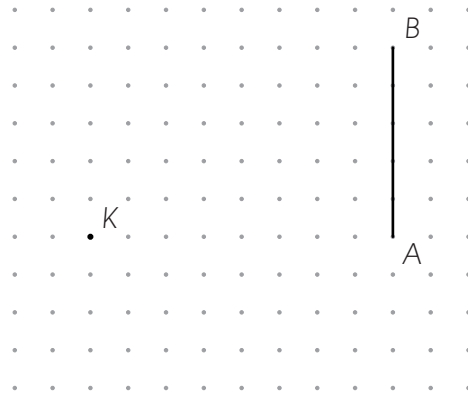
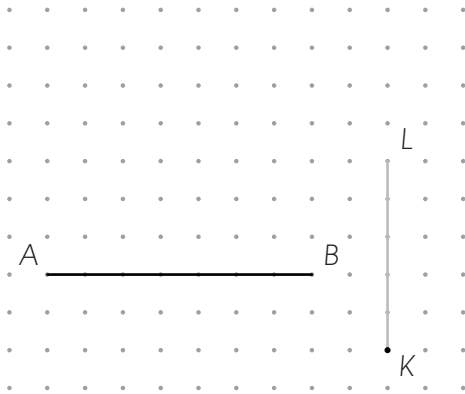

Punktowce dla klas 1–8 to nowatorskie ćwiczenia do rozwijania wyobraźni geometrycznej. Kupisz na www.ksiegarnia.gwo.pl

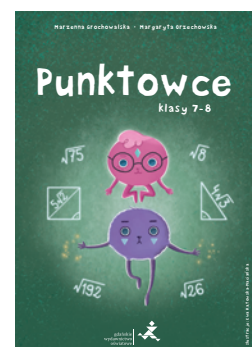

Punktowce

ćwiczenia rozgrzewkowe dla klas 4-6



30. Narysuj odcinek prostopadły do danego odcinka.

Przykładowe rozwiązanie:

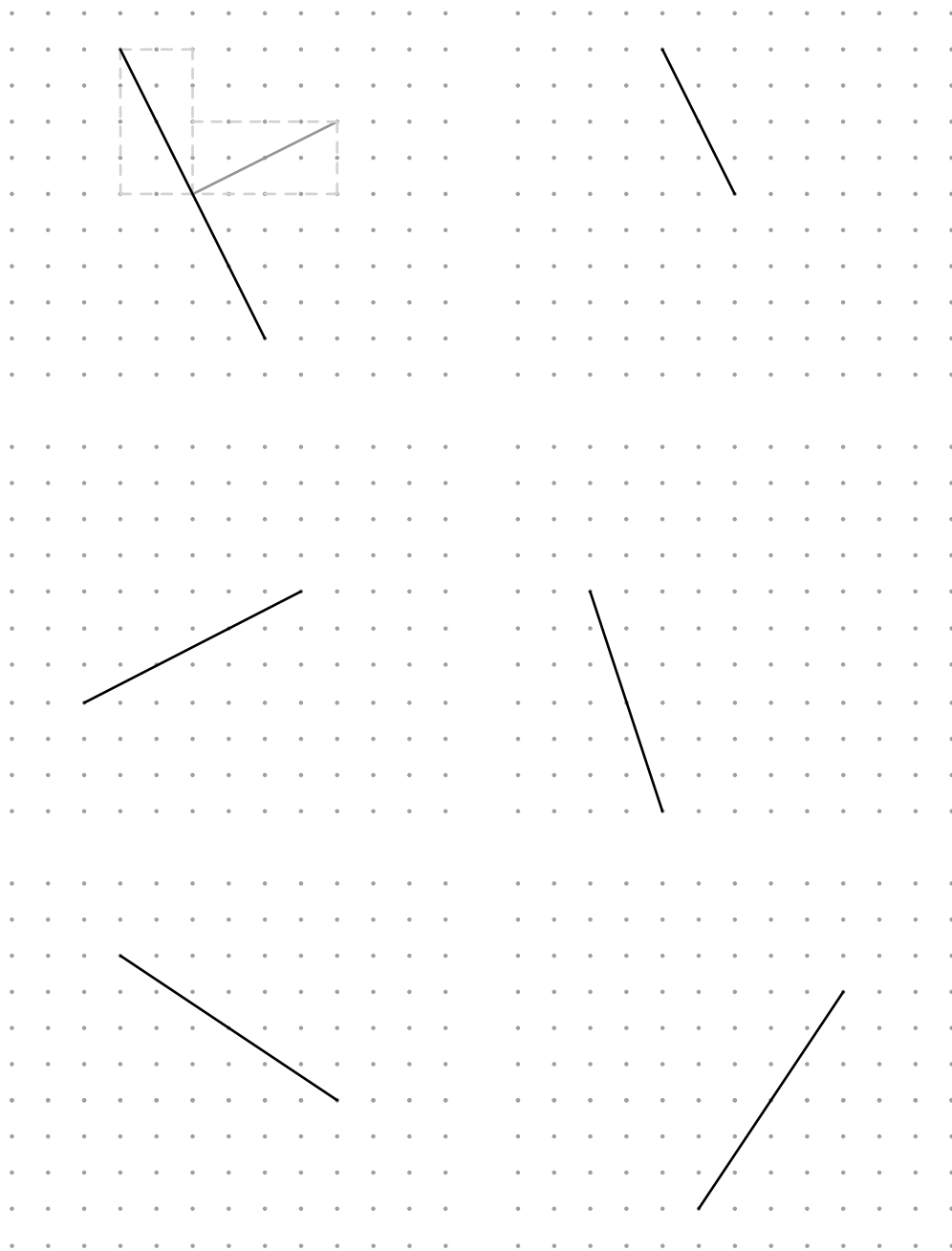

Punktowce dla klas 1–8 to nowatorskie ćwiczenia do rozwijania wyobraźni geometrycznej. Kupisz na www.księgarnia.gwo.pl

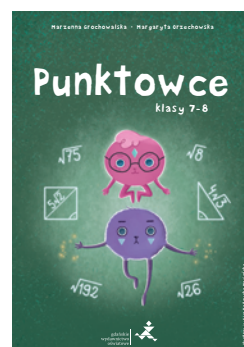

Punktowce

ćwiczenia rozgrzewkowe dla klas 4-6



31. Narysuj odcinek prostopadły do danego odcinka.

Przykładowe rozwiązanie:

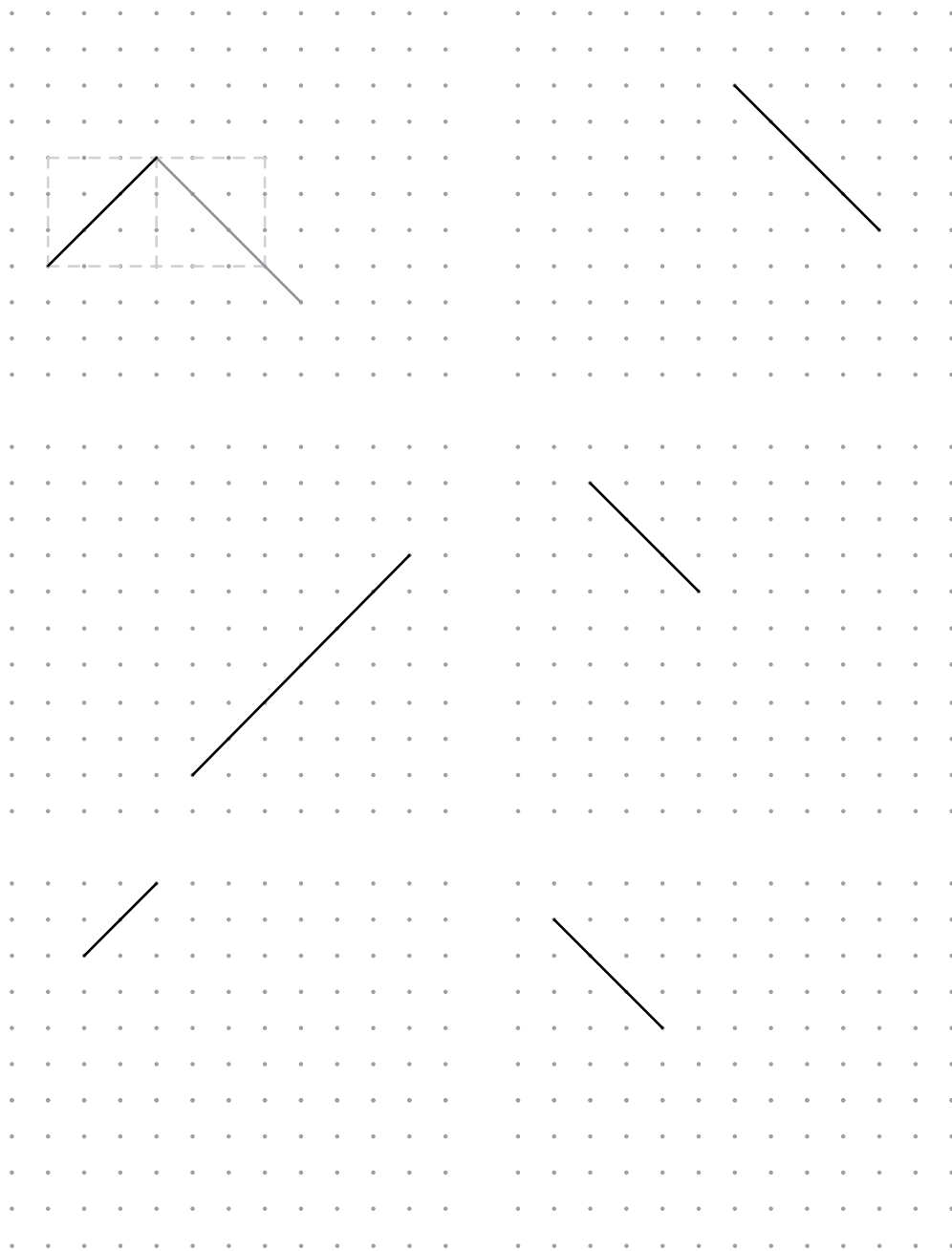

Punktowce dla klas 1–8 to nowatorskie ćwiczenia do rozwijania wyobraźni geometrycznej. Kupisz na www.księgarnia.gwo.pl



Punktowce

ćwiczenia rozgrzewkowe dla klas 4-6



32. Narysuj odcinek prostopadły do danego odcinka, przechodzący przez punkt A.

Przykładowe rozwiązanie:

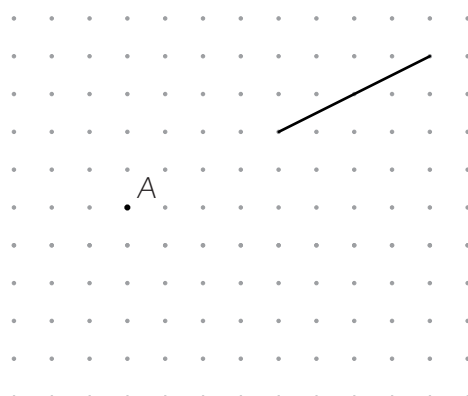
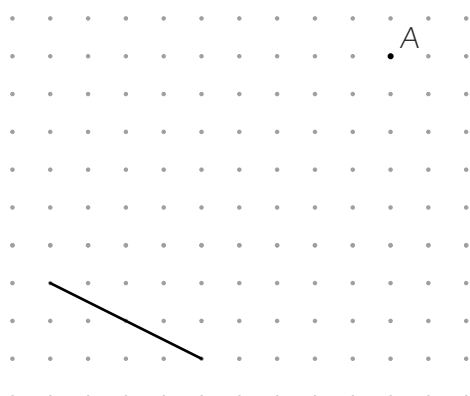
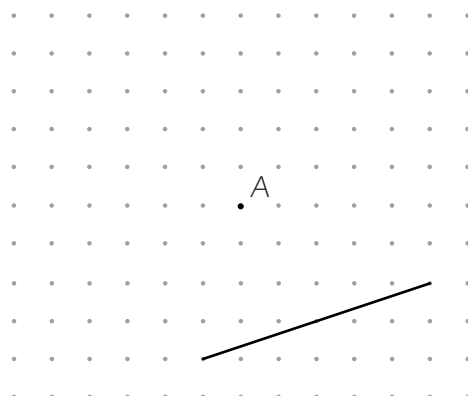
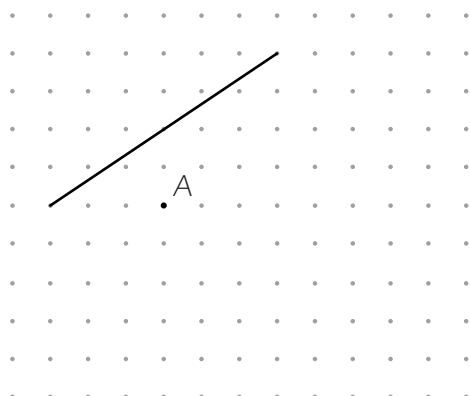
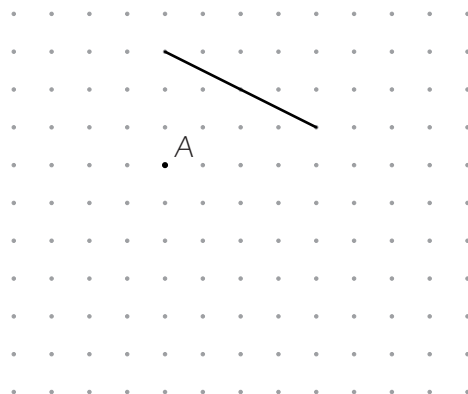
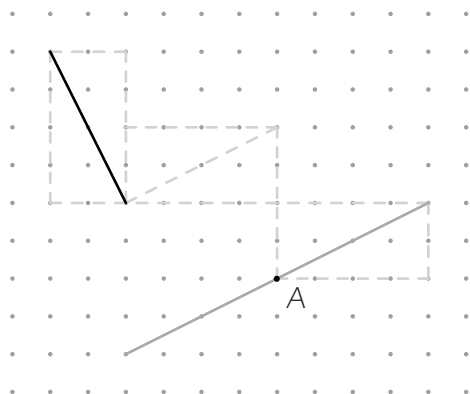

Punktowce dla klas 1–8 to nowatorskie ćwiczenia do rozwijania wyobraźni geometrycznej. Kupisz na www.księgarnia.gwo.pl

